

EXERCICE 1: DESSINER la coupe A-A

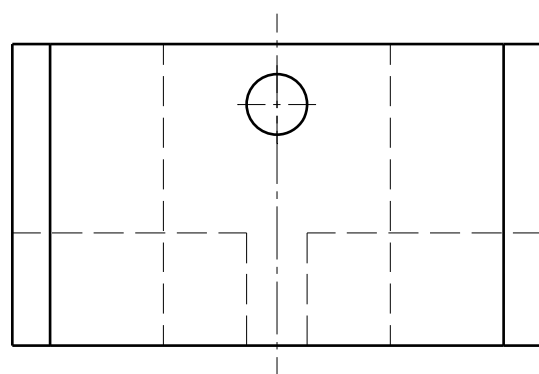

EXERCICE 2: Dessinez la vue de dessus et la coupe A-A de la pièce ci-dessous  
(Epaisseur 10mm)

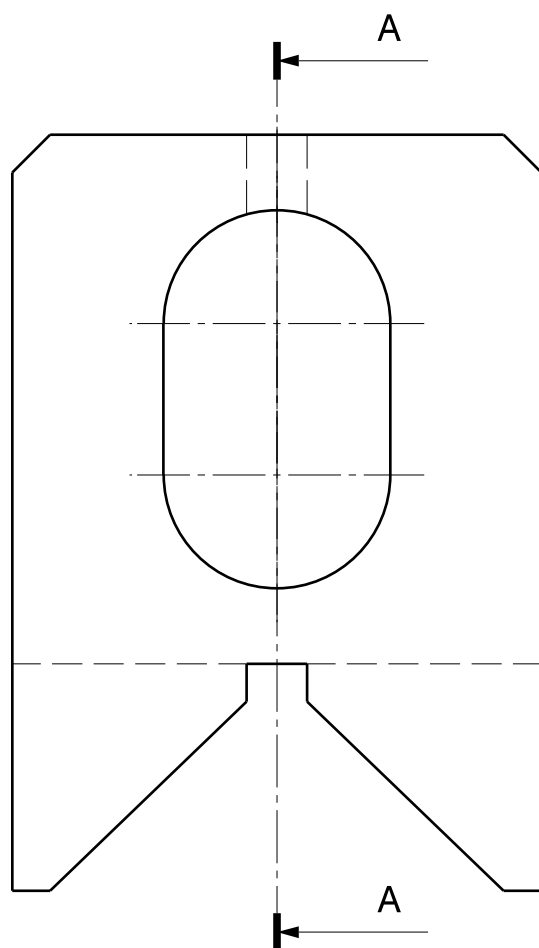
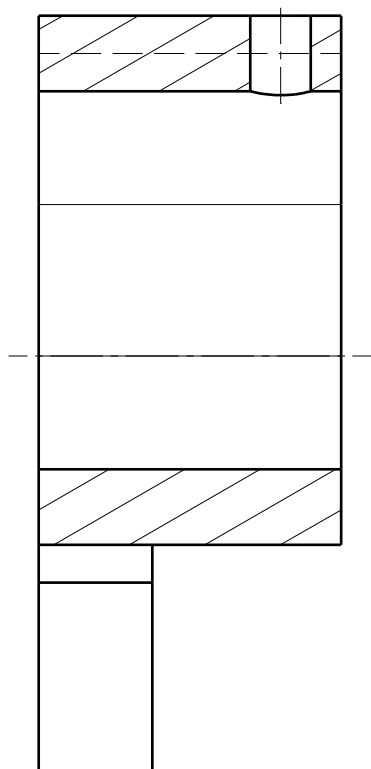
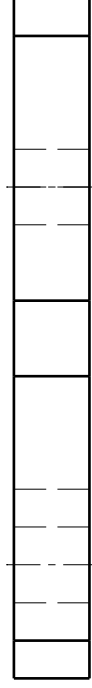
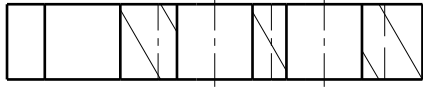
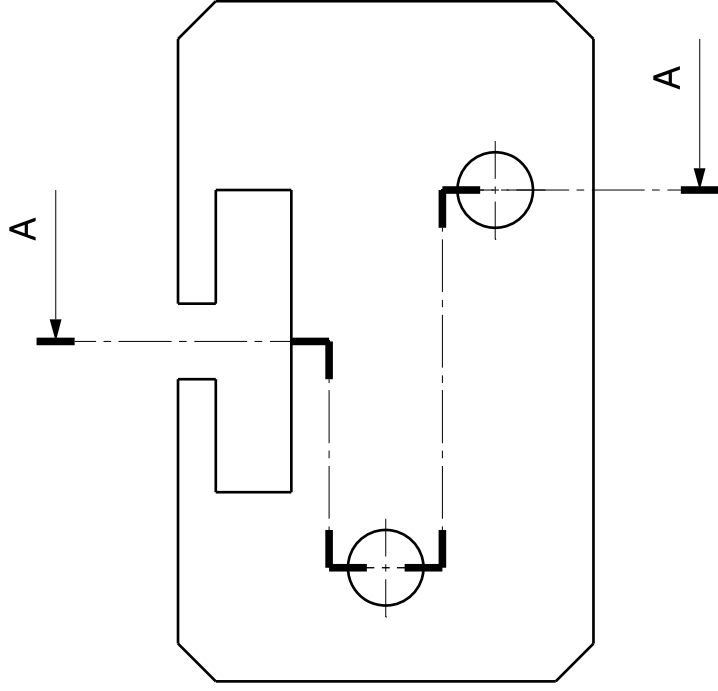

EXERCICE 3: TERMINEZ LES TROIS VUES

Coupe A-A

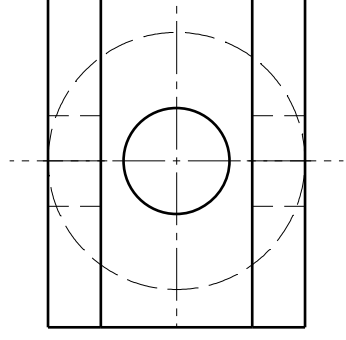
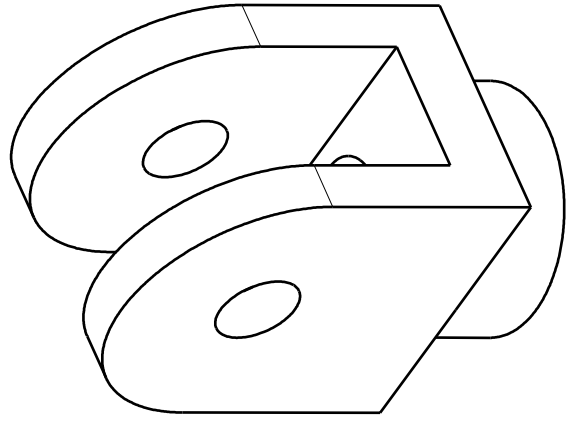
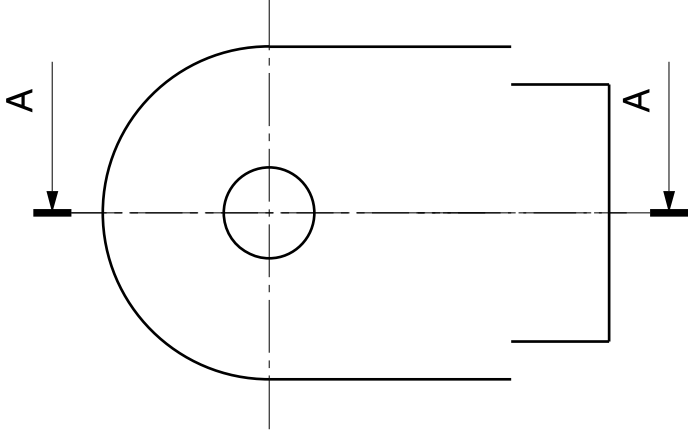
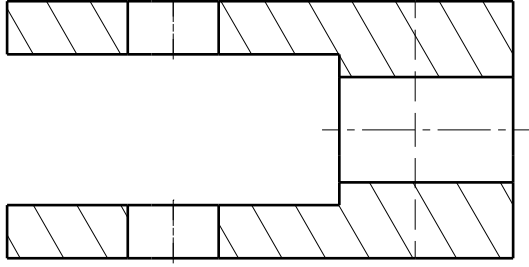

EXERCICE 4: Terminez la vue de dessus, la vue de face en coupe A-A et la vue de droite.

Echelle 3:2

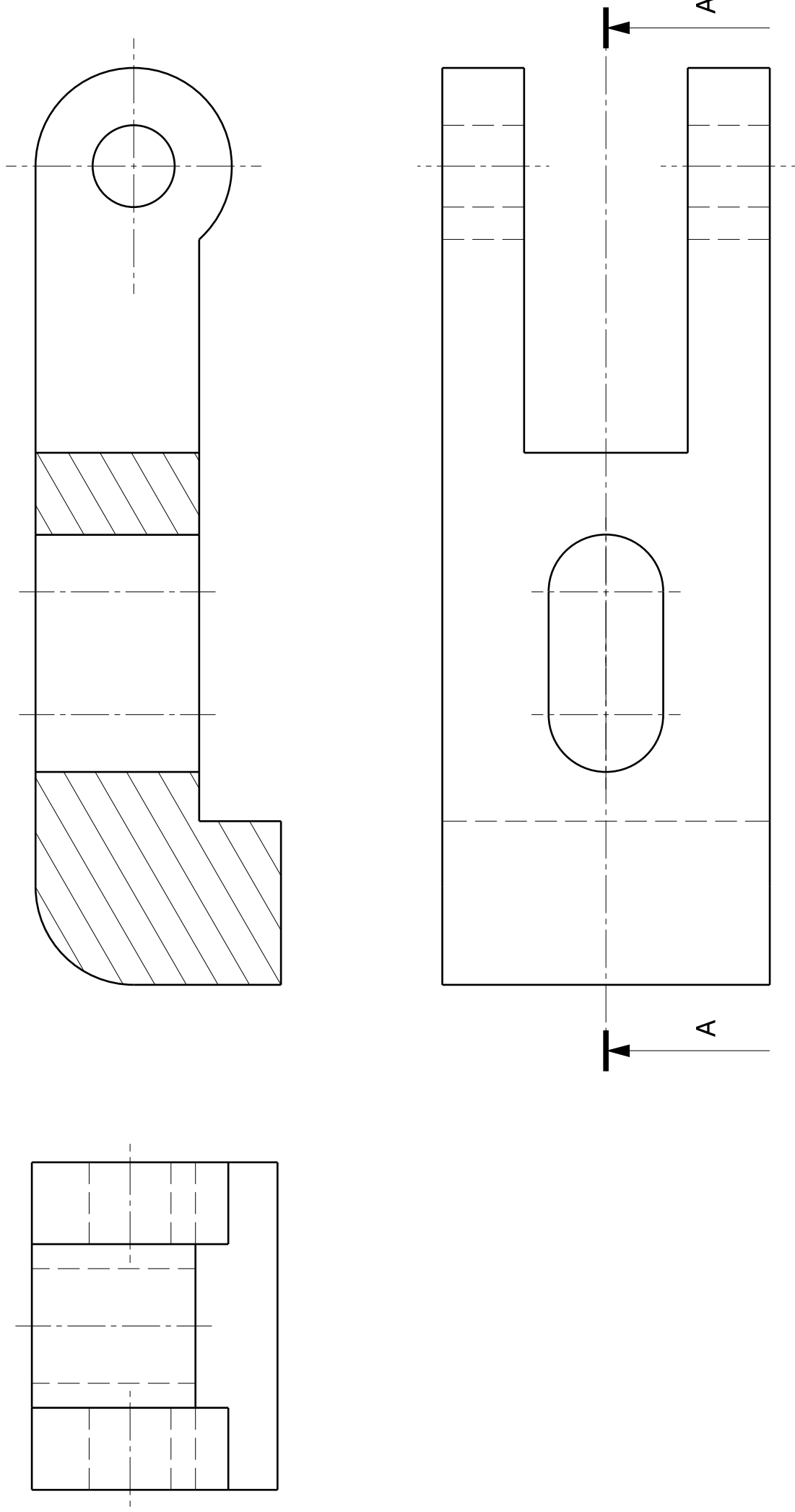

EXERCICE 5: Terminez la demi-coupe A-A, la coupe B-B et la vue de face

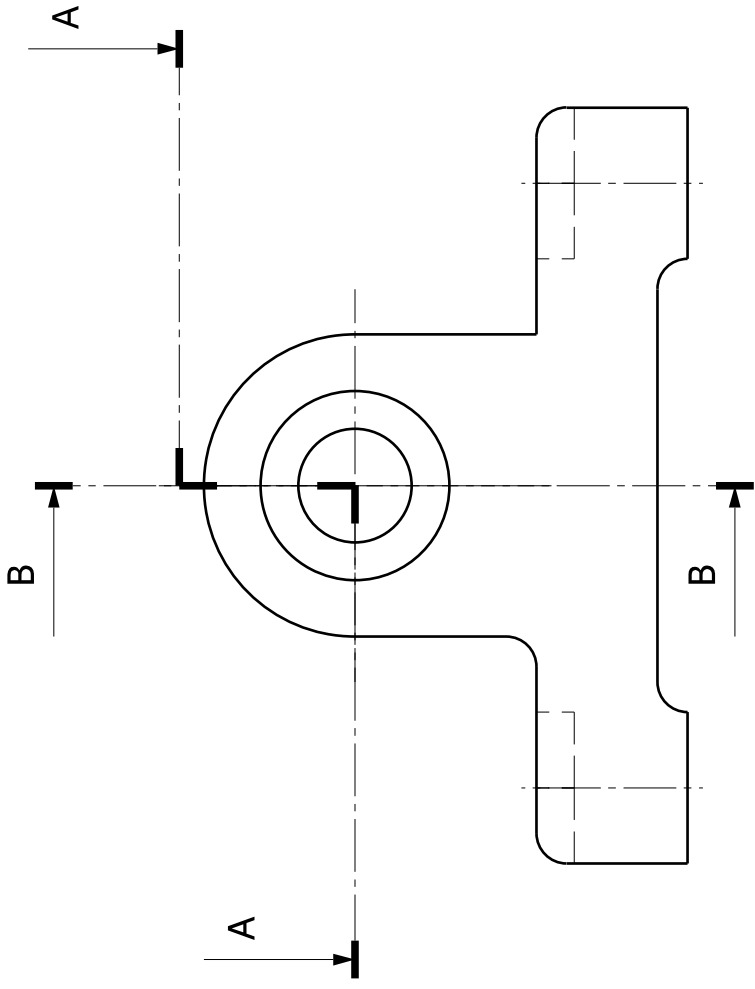

B-B

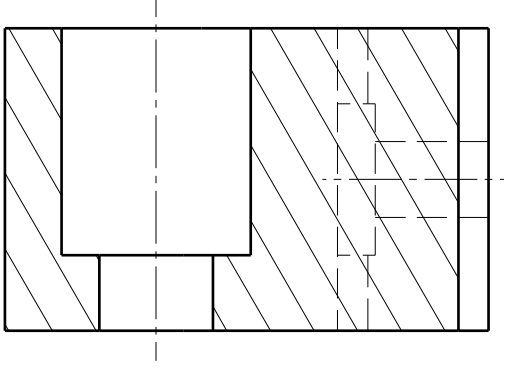

A-A

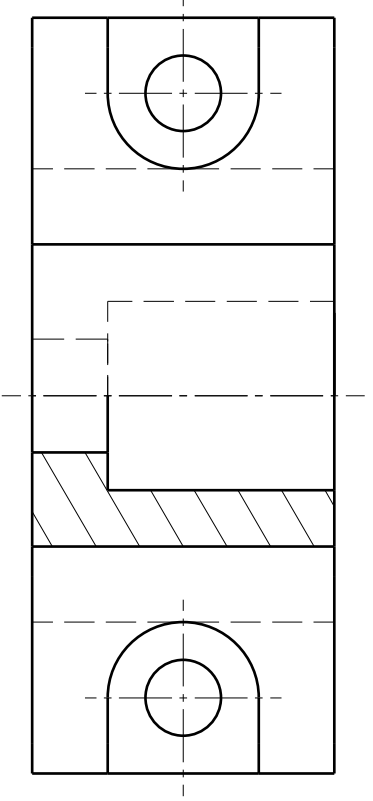

EXERCICE 6: Terminez les trois vues - Echelle 3:2

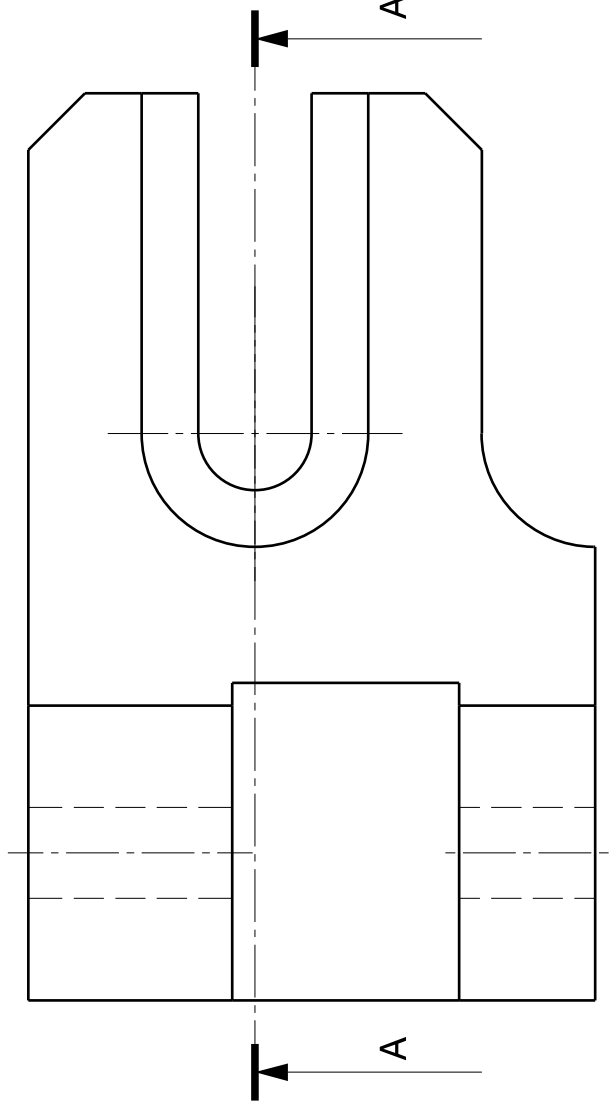
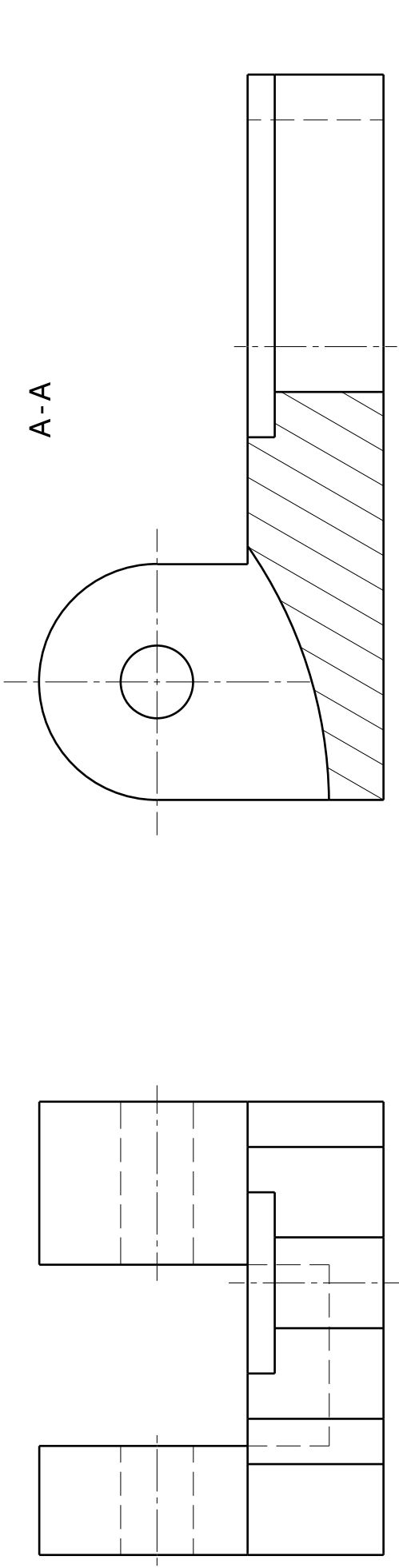

EXERCICE 7: Terminez les trois vues - Echelle 3:2

A-A

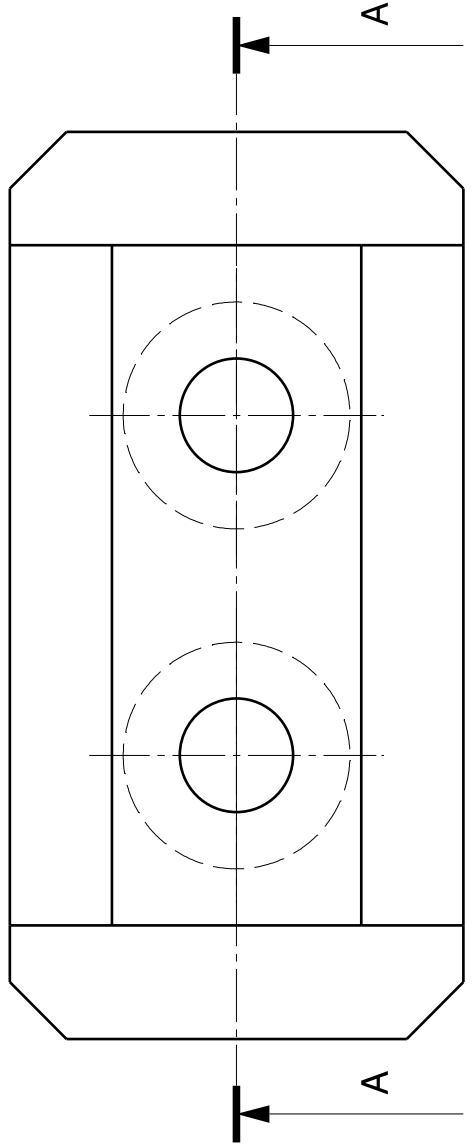
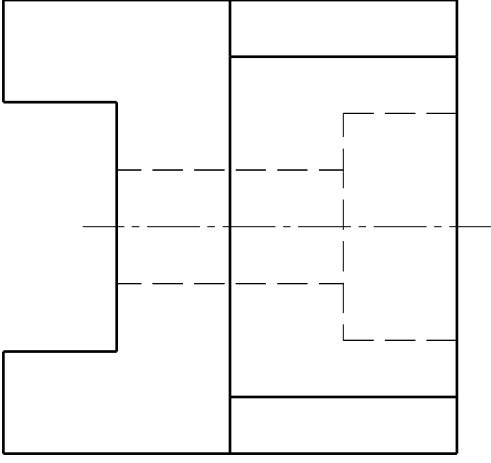
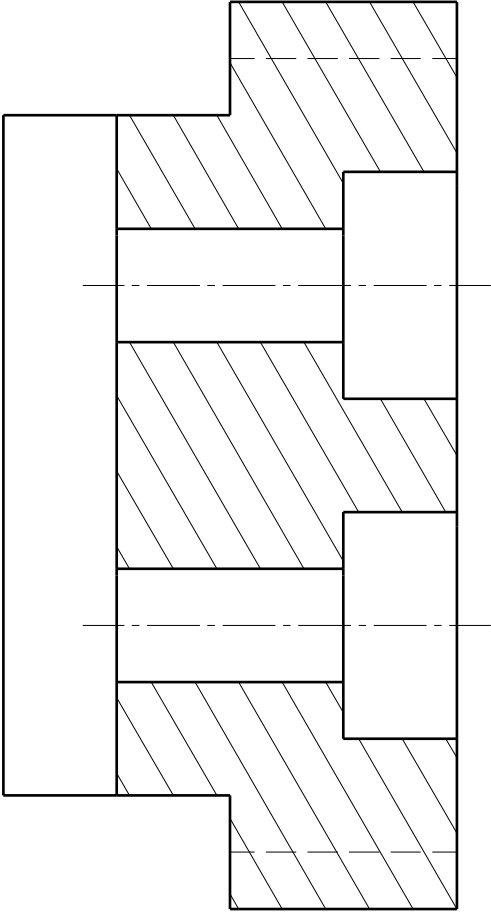

EXERCICE 8: Dessiner la vue de droite (Echelle 3:2)

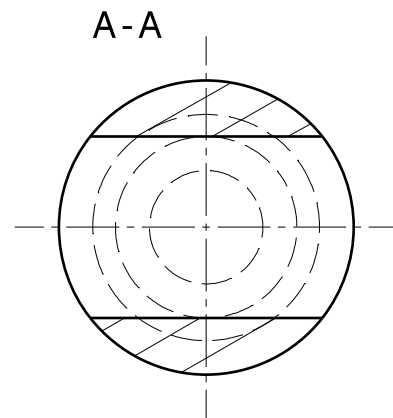
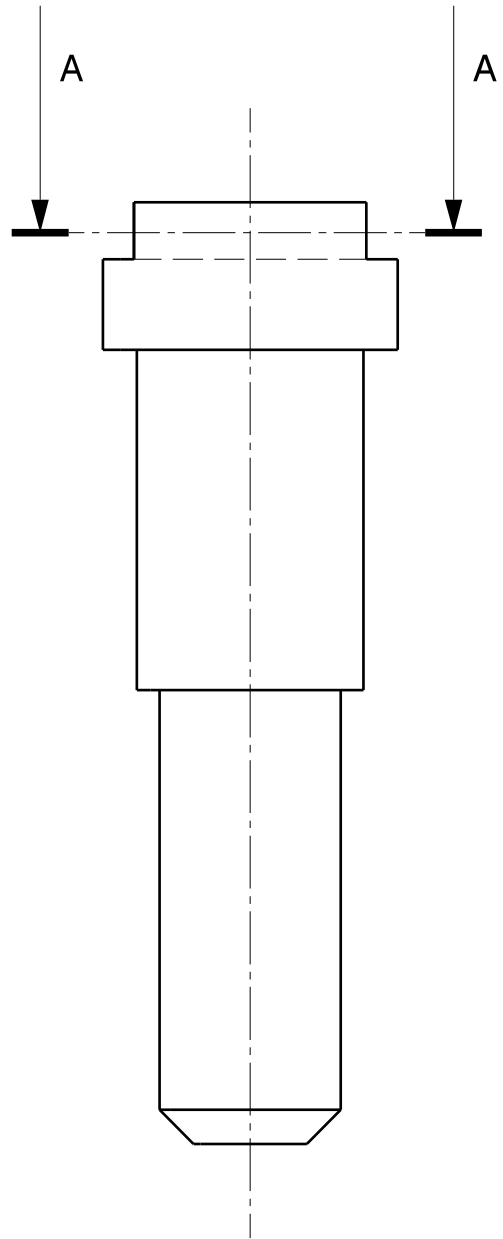
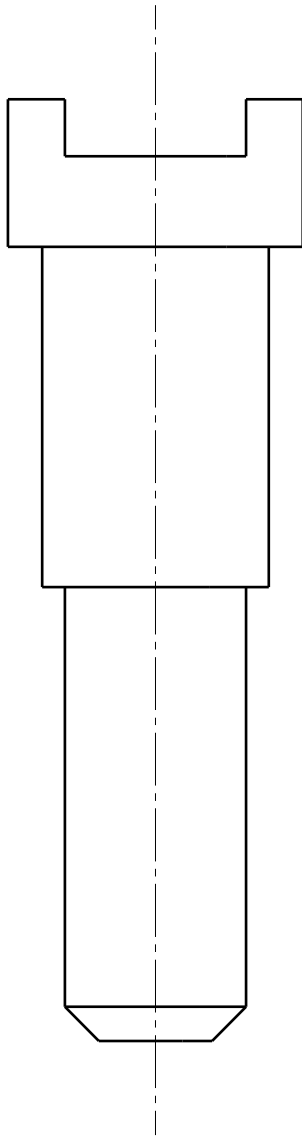



D

C

B

A

A-A

A

4

4

3

3

2

2

1

1

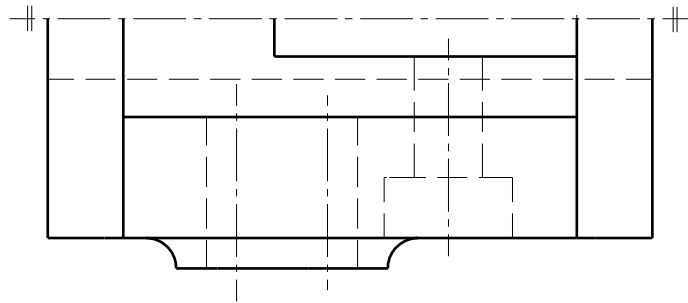
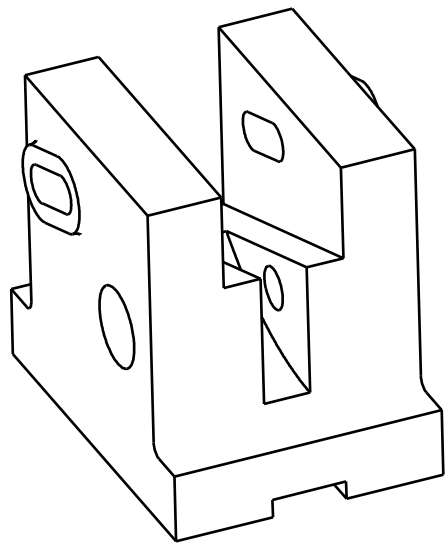
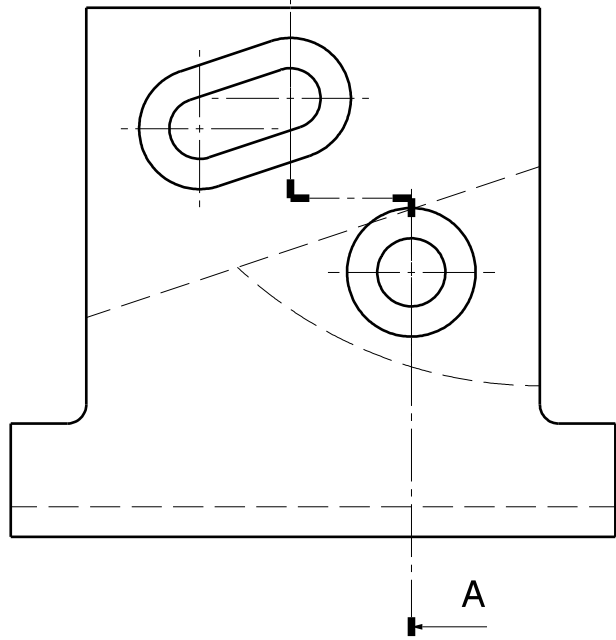
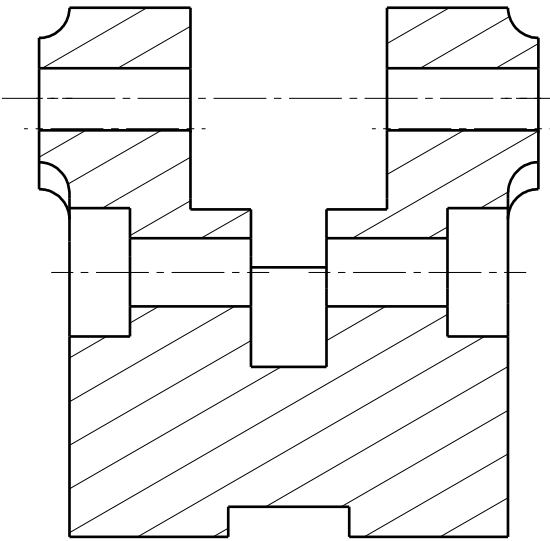

DESIGNED BY:  
**Luc Saint-Sulpice**  
 DATE:  
**16/04/2014**

CHECKED BY:  
 DATE:

SIZE  
**A4**

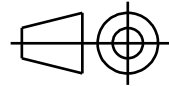

SCALE  
**1:2**

WEIGHT (kg)

**Contre-pointe**

**ENIB**

Prénom Nom

SHEET  
**1 / 1**

I	-
H	-
G	-
F	-
E	-
D	-
C	-
B	-
A	-

This drawing is our property; it can't be reproduced or communicated without our written agreement.

D

A

D

C

B

A

4

4

3

3

2

2

1

1

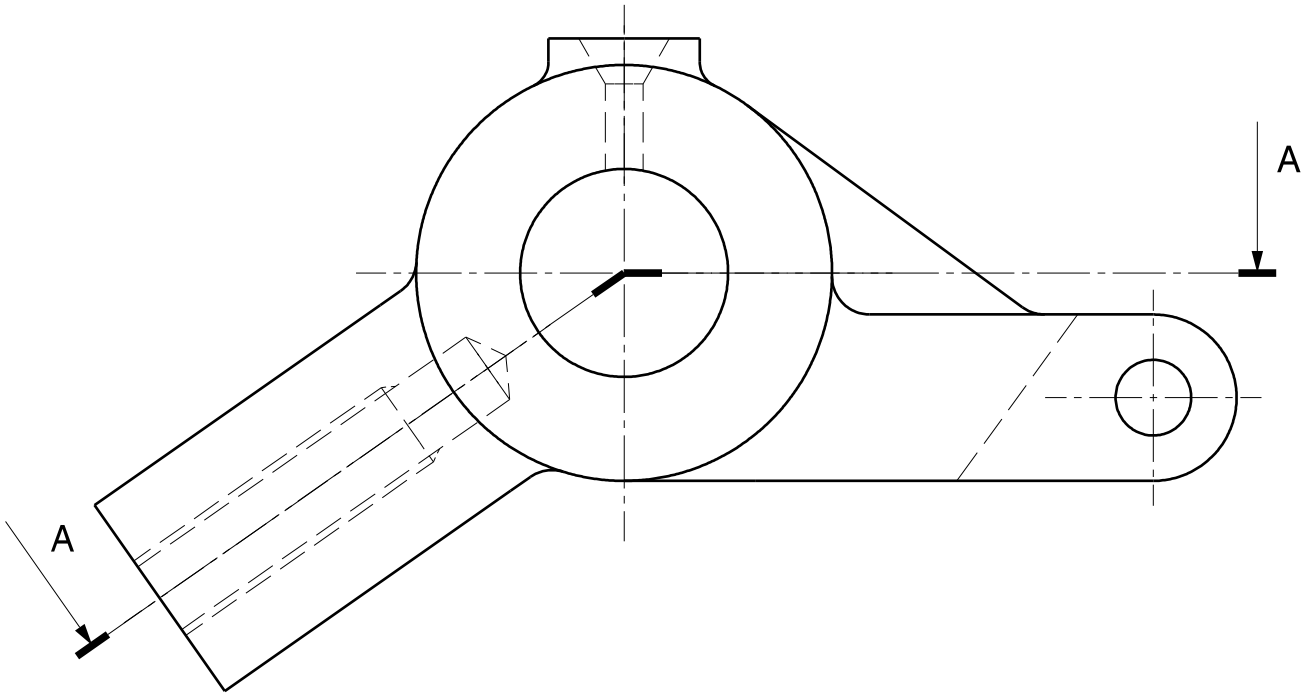

A-A

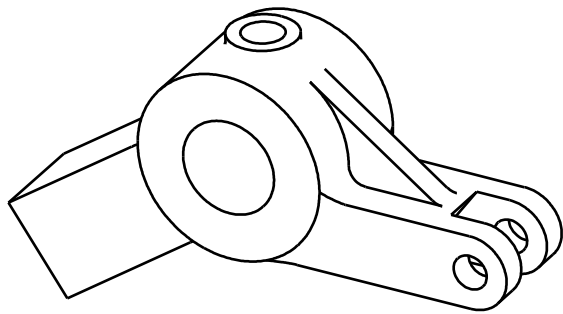
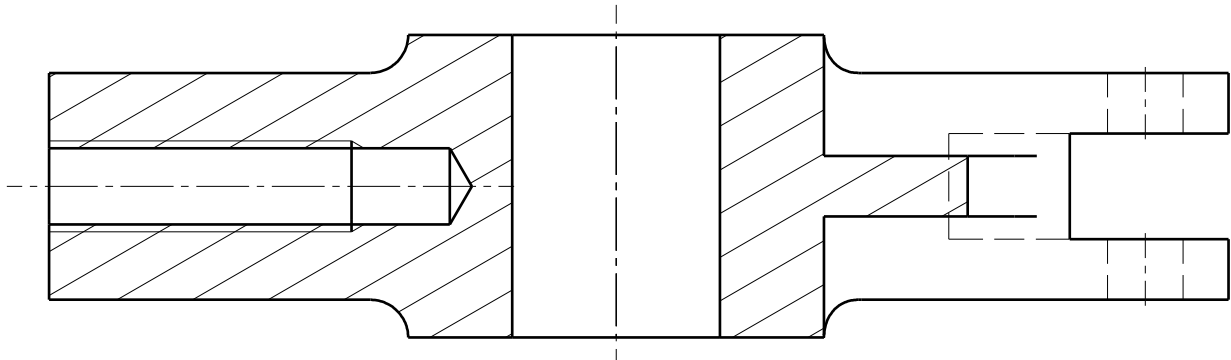

DESIGNED BY:  
**Luc Saint-Sulpice**  
 DATE:  
**09/04/2014**

CHECKED BY:  
 DATE:

SIZE  
**A4**

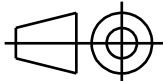

SCALE  
**1:1**

WEIGHT (kg)

**Basculeur**

**ENIB**

Prénom Nom

SHEET  
**1 / 1**

I	-
H	-
G	-
F	-
E	-
D	-
C	-
B	-
A	-

This drawing is our property; it can't be reproduced or communicated without our written agreement.

D

A

D

C

B

A

A-A

A

4

4

3

3

2

2

1

1

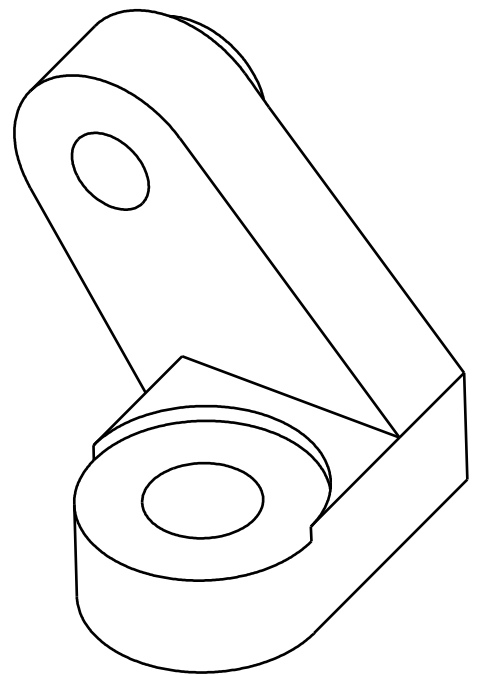
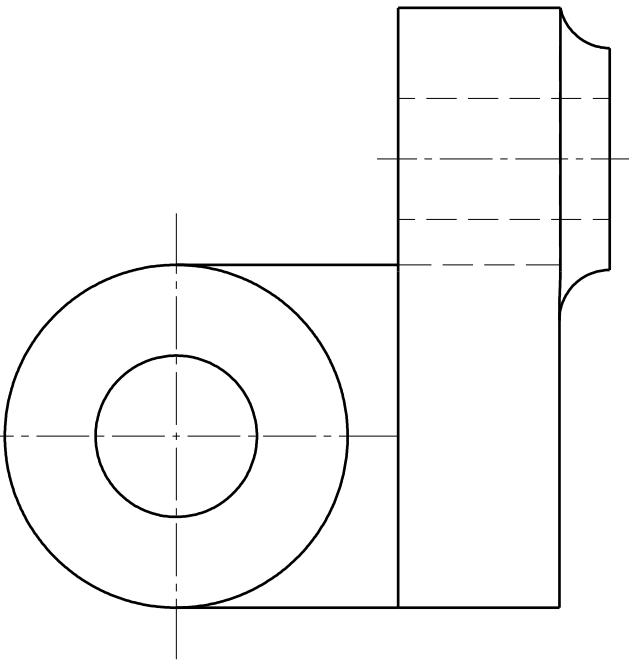
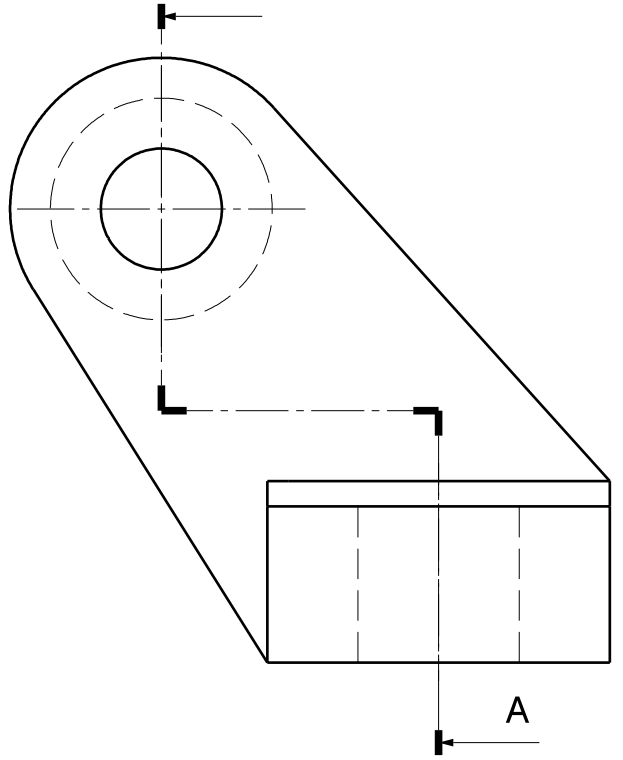
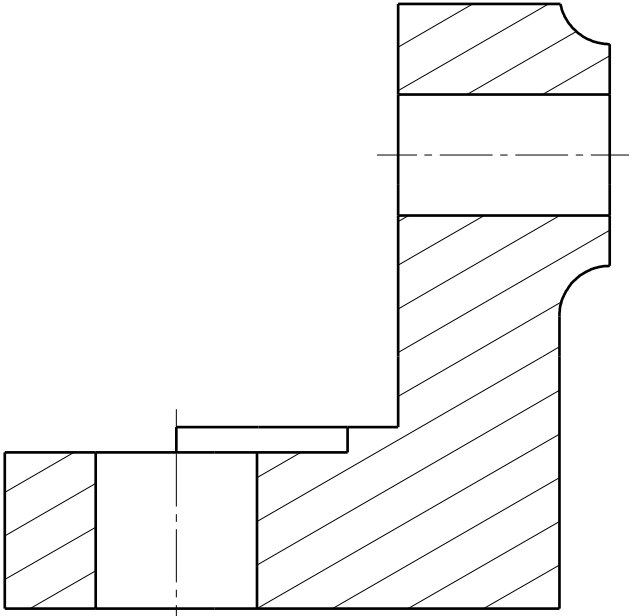

DESIGNED BY:  
**Luc Saint-Sulpice**  
 DATE:  
**16/04/2014**

CHECKED BY:  
 DATE:

SIZE  
**A4**

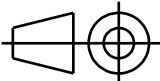

# Equerre

ENIB

SCALE  
**2:3**

WEIGHT (kg)  
**XXX**

Prénom Nom

SHEET  
**1 / 1**

I	-
H	-
G	-
F	-
E	-
D	-
C	-
B	-
A	-

This drawing is our property; it can't be reproduced or communicated without our written agreement.

D

A

D

C

B

A

4

4

3

3

2

2

1

1

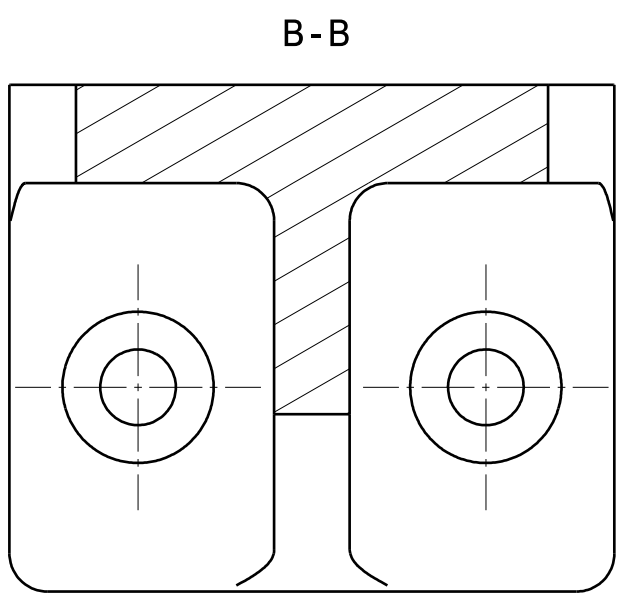
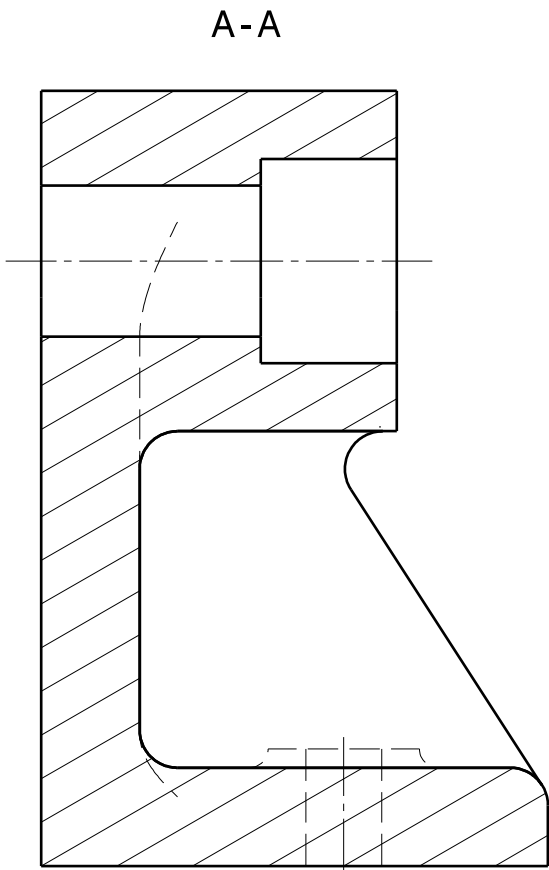
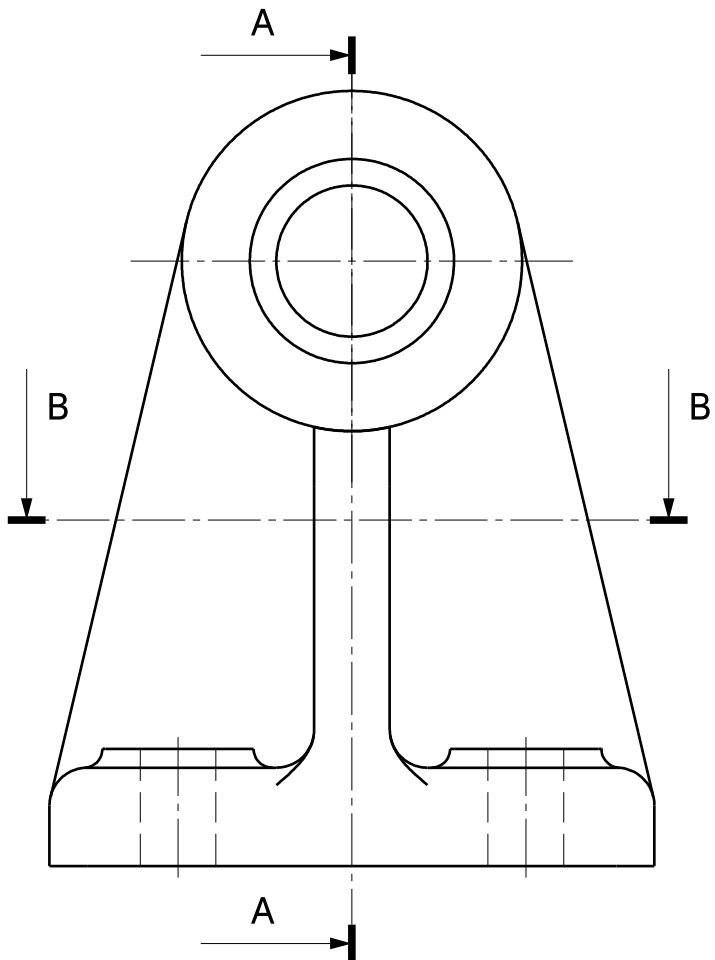

DESIGNED BY: <b>Luc Saint-Sulpice</b>	
DATE: <b>09/04/2014</b>	
CHECKED BY:	
DATE:	
SIZE <b>A4</b>	
SCALE <b>1:1</b>	WEIGHT (kg)

<h1>Support</h1>	
Prénom Nom	
SHEET <b>1 / 1</b>	

I	-
H	-
G	-
F	-
E	-
D	-
C	-
B	-
A	-

This drawing is our property; it can't be reproduced or communicated without our written agreement.

D

A