

Getting started with VL6180X proximity, gesture, ambient light sensor software expansion for STM32Cube

Introduction

STMicroelectronics has introduced various evaluation and development tools to facilitate the integration of the VL6180X sensor in customer's applications.

The VL6180X is a time-of-flight 3-in-1 proximity, gesture and ALS sensor, based on ST patented FlightSense™ technology.

This document provides detailed firmware installation guidelines for:

- Standalone operation
- PC graphical user interface (GUI)
- Application programming interface (API) for the use of VL6180X sensor.

The following list of evaluation devices are available:

- Two Nucleo packs:
 - The P-NUCLEO-6180X1: Includes STM32F401RE Nucleo and X-NUCLEO-6180XA1 expansion boards
 - The P-NUCLEO-6180X2: Includes STM32L053R8 Nucleo and X-NUCLEO-6180XA1 expansion boards
- The X-NUCLEO-6180XA1 expansion board, this board can be used with all STM32 nucleo boards.
- The VL6180X-SATEL: Includes two VL6180X satellite boards. Up to three VL6180X satellite boards can be connected on the X-NUCLEO-6180XA1 expansion board.

Figure 1. P-NUCLEO-6180X1 Nucleo pack

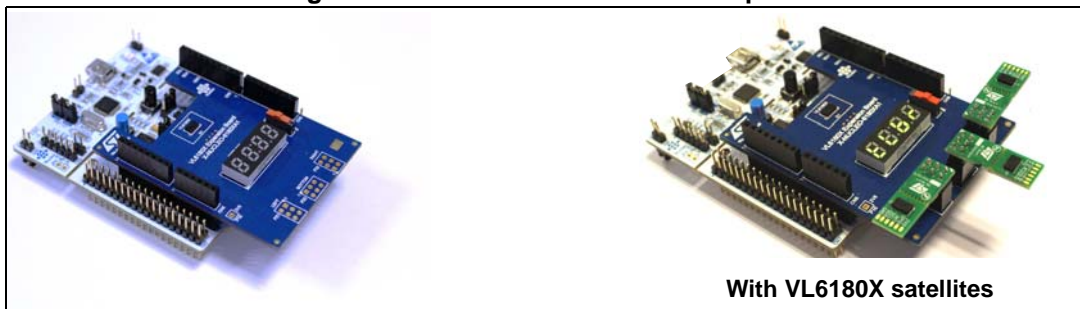

Table 1. Ordering information

Ordering code	Description
P-NUCLEO-6180X1	X-NUCLEO-6180XA1 and STM32F401RE Nucleo boards
P-NUCLEO-6180X2	X-NUCLEO-6180XA1 and STM32L053R8 Nucleo boards
X-NUCLEO-6180XA1	VL6180X expansion board for STM32 Nucleo board family
VL6180X-SATEL	Two VL6180X satellite boards

Contents

1	Introduction	4
1.1	Document references	4
1.2	Hardware description	4
2	What is STM32Cube?	5
3	How does this software complement STM32Cube?	5
4	VL6180X Nucleo pack software installation	6
4.1	STM32 Nucleo board software suite installation	6
4.1.1	STSW-LINK009: STM32 Nucleo board Windows USB driver installation	6
4.1.2	STSW-LINK007: STM32 Nucleo board PC communication driver	8
5	VL6180X standalone demonstrations	9
5.1	Installation of the VL6180X standalone operation	9
5.2	“RangingAndALS” demonstration	13
5.2.1	Ranging mode	13
5.2.2	ALS mode	19
5.3	“RangingWithSatellites” demonstration	20
5.4	“GestureDetect1” demonstration	22
5.4.1	Ranging mode and single swipe / single tap (TAP_SWIPE_2) mode ..	25
5.4.2	Single directional swipe (DIRSWIPE_1) mode	26
6	VL6180X software graphical user interface (GUI)	29
6.1	Installation of the VL6180X PC software graphical user interface (GUI) .	29
6.2	Ranging tab	32
6.2.1	Signal strength (power) graph	34
6.2.2	Actual distance (ToF) graph	36
6.2.3	Actual distance (ToF) graph showing thresholds	38
6.2.4	Gesture help	39
6.2.5	Dmax	40
6.2.6	High speed	40
6.3	Calibration tab	40
6.3.1	Offset calibration procedure with P-NUCLEO-6180X(i)	40

6.3.2	VL6180X offset and cross-talk calibration in a final product	43
6.4	Ambient light sensor (ALS) tab	46
6.5	Options tab	48
6.5.1	Data Logs options window	48
6.5.2	Help window	49
6.5.3	About window	49
6.6	Data log file	51
6.7	I ² C log file	53
7	Application programming interface (API)	54
8	Revision history	56

1 Introduction

Note: In this document P-NUCLEO-6180X(i) stand for P-NUCLEO-6180X1 and P-NUCLEO-6180X2.

1.1 Document references

Table 2. Document references

Description	DocID
Datasheet - VL6180X proximity and ambient light sensing (ALS) module	DocID026171
Data brief - Proximity, gesture, ambient light sensor expansion board based on VL6180X for STM32F401RE	DocID027616
Data brief - Proximity, gesture, ambient light sensor expansion board based on VL6180X for STM32L053R8	DocID027625
Data brief - Proximity and ambient light sensor expansion board based on VL6180X for STM32 Nucleo	DocID027252
Data brief - P-NUCLEO-6180X1 and P-NUCLEO-6180X2 packs PC graphical user interface (GUI)	DocID027684
Data brief - Proximity, gesture, ambient light sensor software expansion for STM32Cube	DocID027687
Data-brief - VL6180X application programming interface (API)	DocID027370
Data-brief - VL6180X satellite boards compatible with VL6180X boards	DocID027253

1.2 Hardware description

The X-NUCLEO-6180XA1 expansion board:

- Is compatible with Arduino™ UNO R3 connectors.
- Must be plugged into an STM32 Nucleo board.
- Can be superposed with all ST expansion boards, which allows, for example, to develop VL6180X applications with Bluetooth or Wifi interface.

The STM32 Nucleo board is connected to the PC via a mini USB connector.

2 What is STM32Cube?

STMCube™ represents an original initiative by STMicroelectronics to ease developers' life by reducing development effort, time and cost. STM32Cube covers the STM32 portfolio.

Version 1.x of STM32Cube includes:

- STM32CubeMX, a graphical software configuration tool that allows the generation of C initialization code using graphical wizards
- A comprehensive embedded software platform, delivered per series (such as the STM32CubeF4 for STM32F4 series)
- STM32Cube HAL, an STM32 abstraction layer embedded software, ensuring maximized portability across the STM32 portfolio
 - A consistent set of middleware components, such as RTOS, USB, TCP/IP, graphics
 - All embedded software utilities, including a full set of examples

3 How does this software complement STM32Cube?

The proposed software is based on the STM32CubeHAL, the hardware abstraction layer for the STM32 microcontroller. The package extends STM32Cube by providing a Board Support Package (BSP) for the X-NUCLEO-6180X expansion board and a VL6180X API component (in Drivers\BSP\Components\VL6180x directory) to program, control and get ranging/ALS values from the VL6180X device.

Several example projects are included in the Projects\Multi\Examples\VL6180X directory, the developer can use these examples to start experimenting with the code. These examples are ready to be compiled using Keil (MDK-ARM), IAR (EWARM) or STM32 Workbench (SW4STM32):

- **RangingAndALS** example features
 - Ranging or ALS modes
 - Selectable scaling in ranging mode
 - Interrupt mode in ranging mode
 - Ranging and ALS measures displayed on 7-segment display
- **RangingWithSatellites** example features
 - Simultaneous ranging from main VL6180X plus up to 3 satellites

Ranging measures displayed on 7-segment display.

One example project is included in Projects\Multi\Applications directory:

- **GestureDetect1** example feature
 - Ranging mode
 - Single swipe and single tap detection with on board VL6180X
 - Directional swipes detection with two VL6180X satellites

4 VL6180X Nucleo pack software installation

ST delivers a software suite allowing the user to discover, through standalone demonstrations and a PC graphical user interface (GUI), the VL6180X ranging and ambient light sensing (ALS) features.

4.1 STM32 Nucleo board software suite installation

The Nucleo board software suite is available from www.st.com, this software is compatible with all STM32 Nucleo boards.

This installation software suite consists of:

- **STSW-LINK009**, ST-Link, ST-Link/V2, ST-Link/V2-1 USB driver signed for XP, Windows7 and 8. This driver must be first installed.
- **STSW-LINK007**, ST-Link/V2-1 firmware update.
When STSW-LINK009 and STSW-LINK007 firmware are installed the STM32 Nucleo board is configured and ready to use with a PC.

4.1.1 STSW-LINK009: STM32 Nucleo board Windows USB driver installation

- On www.st.com home page search for “STSW-LINK009”

Figure 2. STM32 Nucleo board Windows USB driver installation - step 1



- On next page click on “STSW-LINK009”

Figure 3. STM32 Nucleo board Windows USB driver installation - step 2

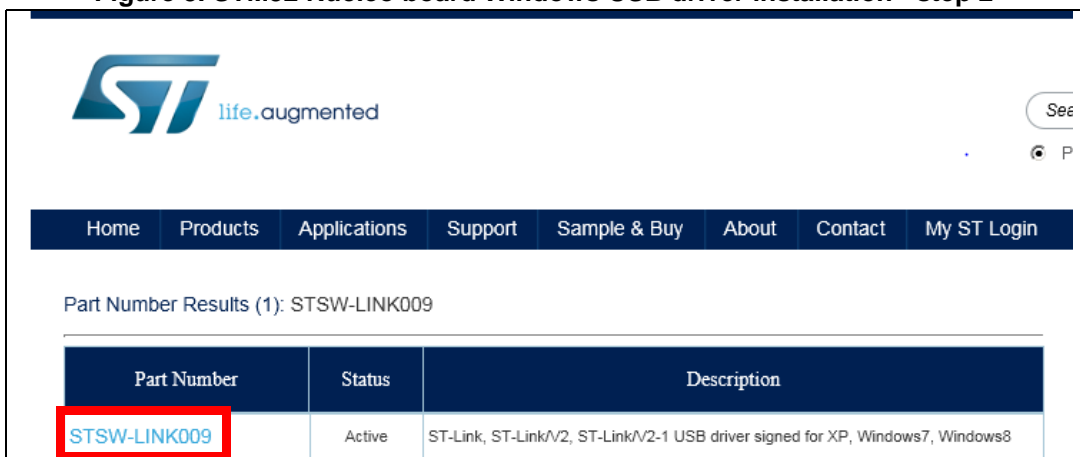

- On next page click on “Download”

Figure 4. STM32 Nucleo board Windows USB driver installation - step 3

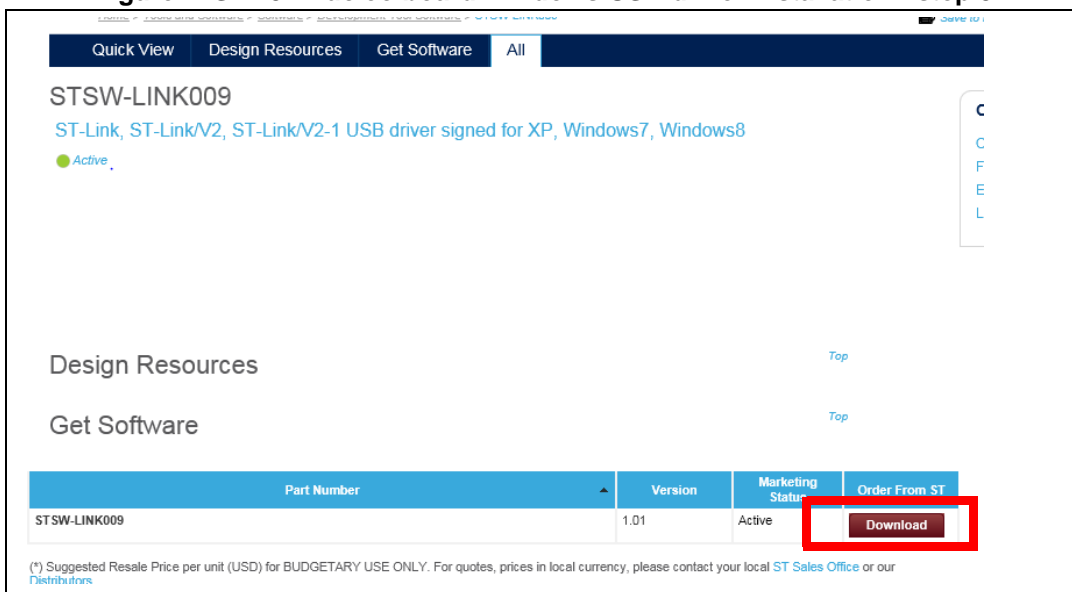

- From stsw-link009.zip, unpack the .zip file and run stlink_winusb_install.bat. This will install the necessary USB drivers to allow communications between the Nucleo board and the PC.

Figure 5. STM32 Nucleo board Windows USB driver installation - step 4

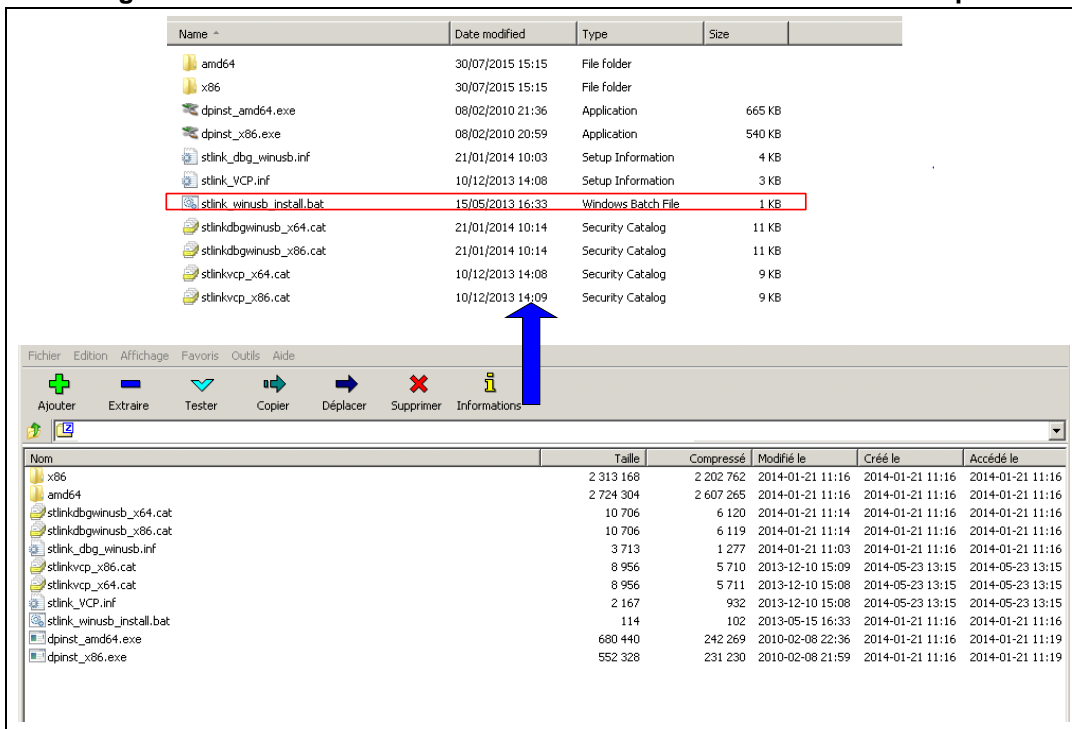

- Plug a USB cable between the PC and STM32 Nucleo board. Allow the board driver installations to complete before proceeding.

4.1.2 STSW-LINK007: STM32 Nucleo board PC communication driver

- To install STSW-LINK007 repeat the steps 1 to 3 performed for the installation of the STSW-LINK009 STM32 Nucleo board Windows USB driver installation.
- Unpack the downloaded stsw-link007.zip file and run STLinkUpgrade.exe.
- Ensure the Nucleo board is connected via the USB port.
- Click 'device connect' on the dialogue and confirm the board has successfully connected.
- When prompted to upgrade to the latest version check that the suggested version is later than the current firmware version then, click 'YES' to proceed.

Figure 6. STM32 Nucleo board communication driver with PC installation - step 4

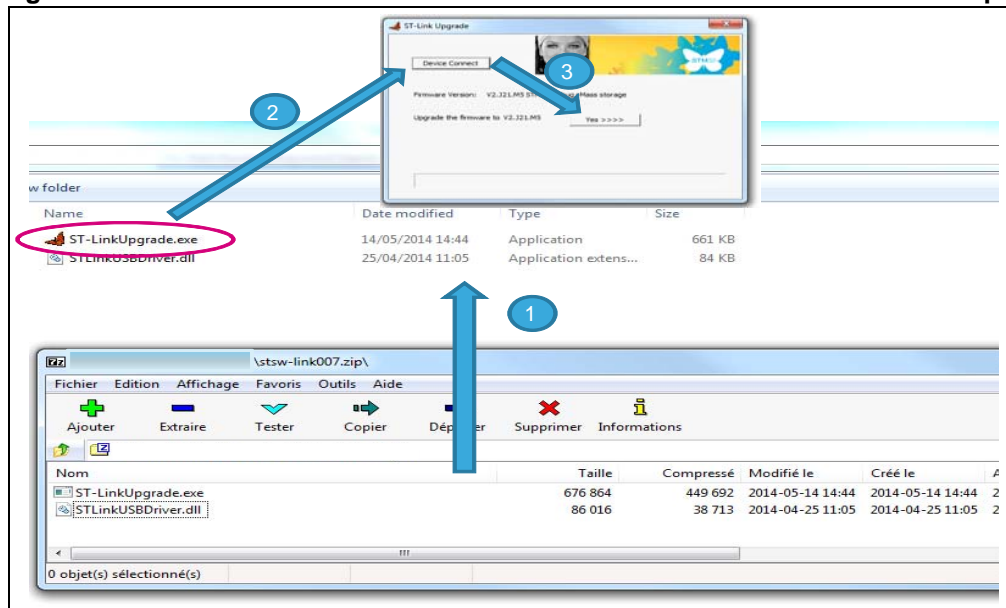

5 VL6180X standalone demonstrations

5.1 Installation of the VL6180X standalone operation

Note: If not already done, plug VL6180X expansion board on to STM32 Nucleo board

To install VL6180X standalone demonstrations.

- In P-NUCLEO-6180X1 or in P-NUCLEO-6180X2 web pages select X-CUBE-6180XA1.

Figure 7. VL6180X standalone demonstration installation - step 1

Related Tools and Software	
Part Number	Description
STSW-LINK007	ST-LINK/V2-1 firmware upgrade
STSW-LINK009	ST-Link, ST-Link/V2, ST-Link/V2-1 USB driver signed for XP, Windows7, Windows8
X-CUBE-6180XA1	Proximity, gesture, ambient light sensor software expansion for STM32Cube
STSW-IMG004	Windows Graphical User Interface (GUI) for VL6180X Evaluation Kits. Works with P-NUCLEO-6180X1, P-NUCLEO-6180X2 and EVALKIT-VL6180X

- Click on “Download” then save it

Figure 8. VL6180X standalone demonstration installation - step 2

Part Number	Version	Marketing Status	Order From ST
X-CUBE-6180XA1	1.1.0	Active	Download

(*) Suggested Resale Price per unit (USD) for BUDGETARY USE ONLY. For quotes, prices in local currency, please contact your local [ST Sales Office](#) or our [Distributors](#)

(**) The Material Declaration forms available on [st.com](#) may be generic documents based on the most commonly used package within a package family. For this reason, they may not be 100% accurate for a specific device. Please contact our [sales support](#) for information on specific devices.

- Unzip the file
- The standalone demonstration software are located in the directory: Nucleo/Projects/Multi/Examples/VL6180X (see [Figure 9](#)).

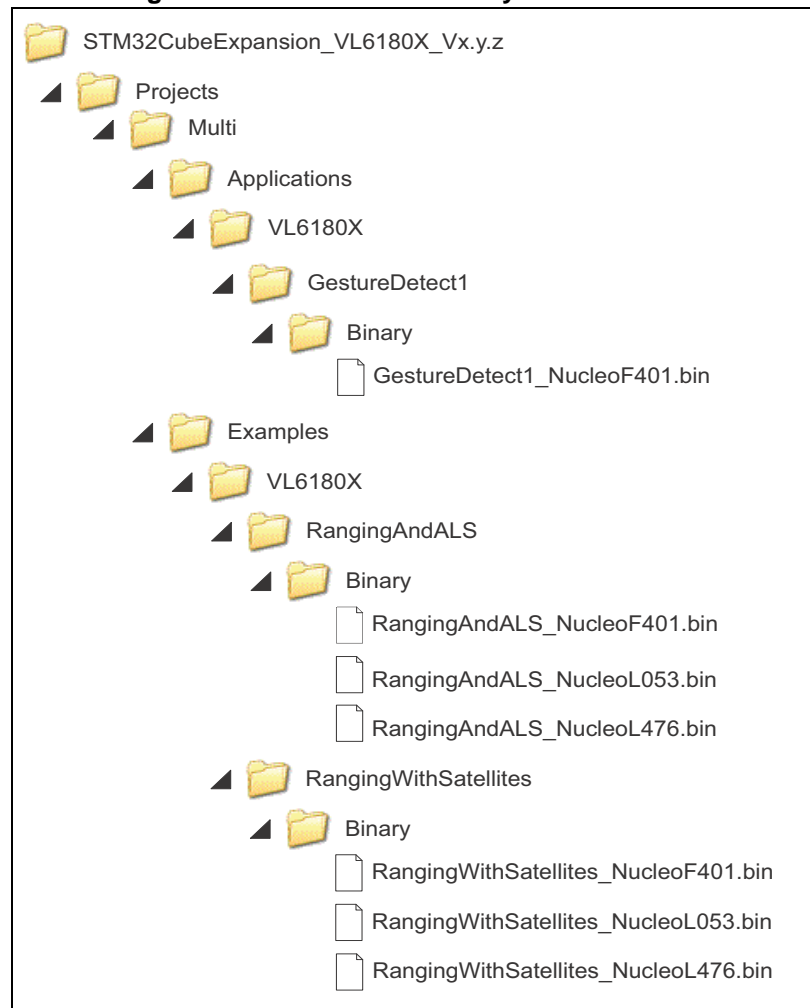
Figure 9. Demonstration binary files location^(a)

- Each example code (RangingAndALS and RangingWithSatellites) can be compiled using one of the provided projects (MDK-ARM, EWARM, SW4STM32) for each Nucleo board type: L476, F401 and L053.
- Pre-compiled binaries are also provided in the Bin directories of each example.
 - For the L053R8, RangingAndALS_NucleoL053.bin and RangingWithSatellites_NucleoL053.bin.
 - For the F401RE, RangingAndALS_NucleoF401.bin and RangingWithSatellites_NucleoF401.bin.
 - For the L476RG, RangingAndALS_NucleoL476.bin and RangingWithSatellites_NucleoL476.bin.
- RangingAndALS_NucleoXXXX.bin shows the behavior of a single VL6180X in ranging and ALS modes (see [Section 5.2: “RangingAndALS” demonstration](#)).
- RangingWith Satellites_NucleoXXXX.bin shows the behavior of four VL6180X in ranging mode (see [Section 5.3: “RangingWithSatellites” demonstration](#)).

a. The list above shows the examples available in the latest version of the STM32CubeExpansion_VL6180X_Vx.y.z. More examples can be added.

- The example code GestureDetect1 can be compiled using one of the provided projects (MDK-ARM, EWARM, SW4STM32).
- A pre-compiled binary is also provided in the Binary directory for this example.
 - GestureDetect1_NucleoF401.bin.

Drag and drop the “.bin” file you want to select to the L053R8 or F401RE or L476RG STM32 Nucleo board.

Figure 10. VL6180X standalone demonstration installation - step 4

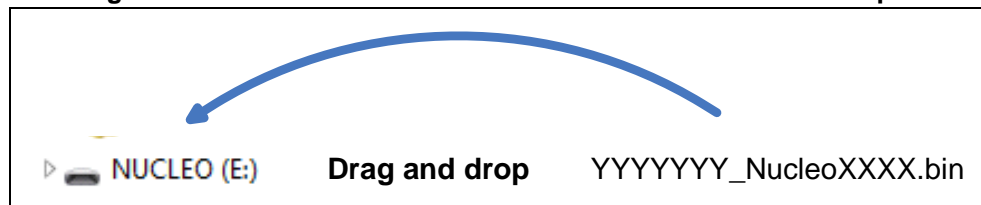

Press the black reset button on the STM32 Nucleo board and release it,

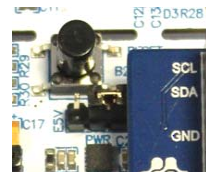

the Nucleo pack is now running in “standalone” mode, meaning no PC is required to control the Nucleo pack, USB connection is only used to power the Nucleo pack.

The switch SW1 can be asserted during any stage of operation.

- When running in Standalone mode, the SW1 switch on the VL6180X expansion board selects the value displayed on the 4-digit display, see [Figure 11](#).
 - If switched to “Range”, the distance detected between VL6180X and the nearest object is displayed in mm.
 - If switched to “ALS”, the ambient light level is displayed in Lux.

Figure 11. Value displayed versus SW1 switch setting

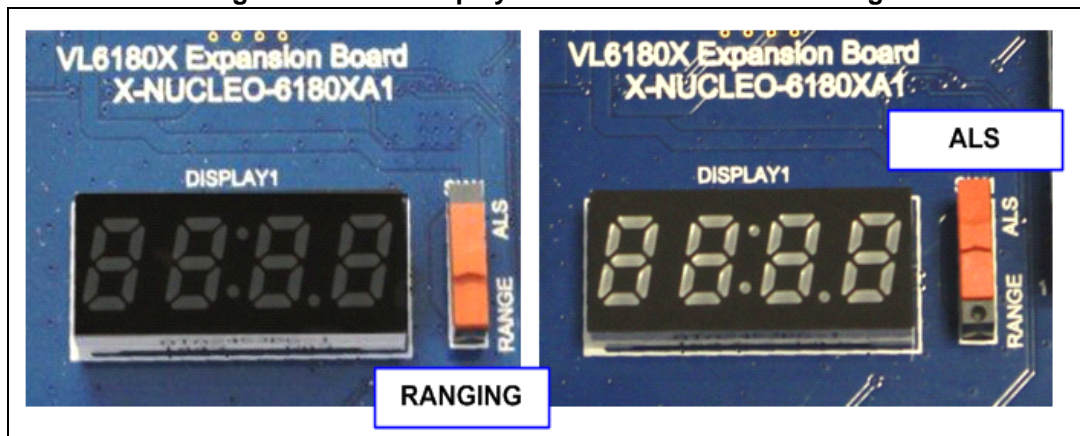

- Move your hand or any object in front of VL6180X and read the value displayed on the 4-digit display.

The VL6180X Nucleo pack provides various demonstration modes for ranging and ambient light sensing:

- Scale Factor Modes (1,2 and 3), to demonstrate the extended ranging performance of the device, with the scale factors applied manually in isolation or automatically.
- Alarm threshold modes, to demonstrate alarm conditions, with the VL6180X sending an interrupt to the application host as range measurements cross pre-defined range threshold limits. The benefit of this interrupt mode is that the host can stay in stand-by mode, reducing power consumption of the system, and the VL6180X will automatically send an interrupt to the host when the thresholds are reached.
- ALS mode, demonstrating the Ambient Light Sensor performance.
- Multiple VL6180X device operation.

These are described in more detail in the following sub-sections.

5.2 “RangingAndALS” demonstration

- Drag and drop the “RangingAndALS_NucleoXXXX.bin” file, which one will depend on whether you use a L053R8 or a F401RE or a L476RG STM32 Nucleo board.

Figure 12. VL6180X standalone RangingAndALS installation - step 4

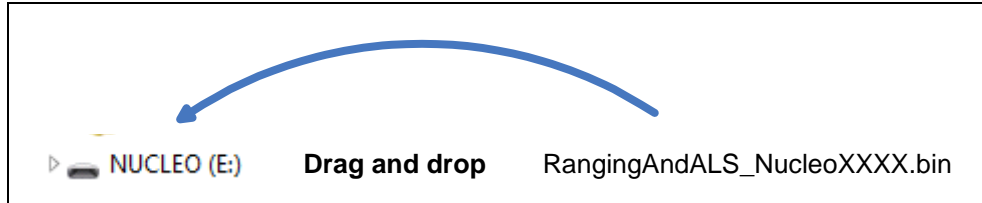

5.2.1 Ranging mode

The switch SW1 must be in “RANGE” mode:



In this ranging mode the left digit displays “r”, see [Figure 13](#), during the ranging measurement.

Figure 13. Left display digit in ranging mode



When the USB cable is plugged in the message “**SF 1**” is displayed for a few seconds (see [Figure 14](#)). This message indicates that VL6180X scaler factor is set to 1. Consequently range measurements between the VL6180X and the target are confined to the limits 0 and 20cm with a granularity of 1mm.

Figure 14. SF 1 message



There are two different types of modes available under RangingAndALS.

- A short press on the STM32 Nucleo board blue button will activate the Scale Factor mode.
- A long press on the STM32 Nucleo board blue button will activate the Alarm threshold mode

After the first short press on the blue button of the STM32 Nucleo board,



the message “**SF 2**” is displayed for a few seconds (see [Figure 15](#)); This message indicates that VL6180X scaler factor is set to 2. Consequently range measurements between the VL6180X and the target are confined to the limits 0 and 40cm with a granularity of 2mm.

Figure 15. SF 2 message



At next short press on the blue button of the STM32 Nucleo board,



the message “**SF 3**” is displayed for a few seconds (see [Figure 16](#)). This message indicates that VL6180X scaler factor is set to 3. Consequently range measurements between the VL6180X and the target are confined to the limits 0 and 60cm with a granularity of 3mm.

Figure 16. SF 3 message

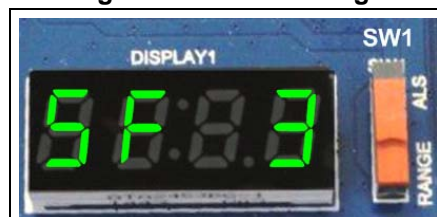

At next short press on the blue button of the STM32 Nucleo board,



the message “SF A” is displayed for a few seconds (see [Figure 17](#)). This message indicates that VL6180X scaler factor is set to automatic mode, resulting in range measurements between the VL6180X and the target being confined to the limits 0 to 60cm with a granularity of of:

- 1mm for the range measurement between 0 and 20cm
- 2mm for the range measurement between 20 and 40cm
- 3mm for range measurement between 40 and 60cm

Figure 17. SF A message



Starting from a USB cable connection, the sequence linked to sequential short presses on the blue button of the STM32 Nucleo board is described in [Figure 18](#).

Figure 18. Range measurement sequence versus short presses on blue button

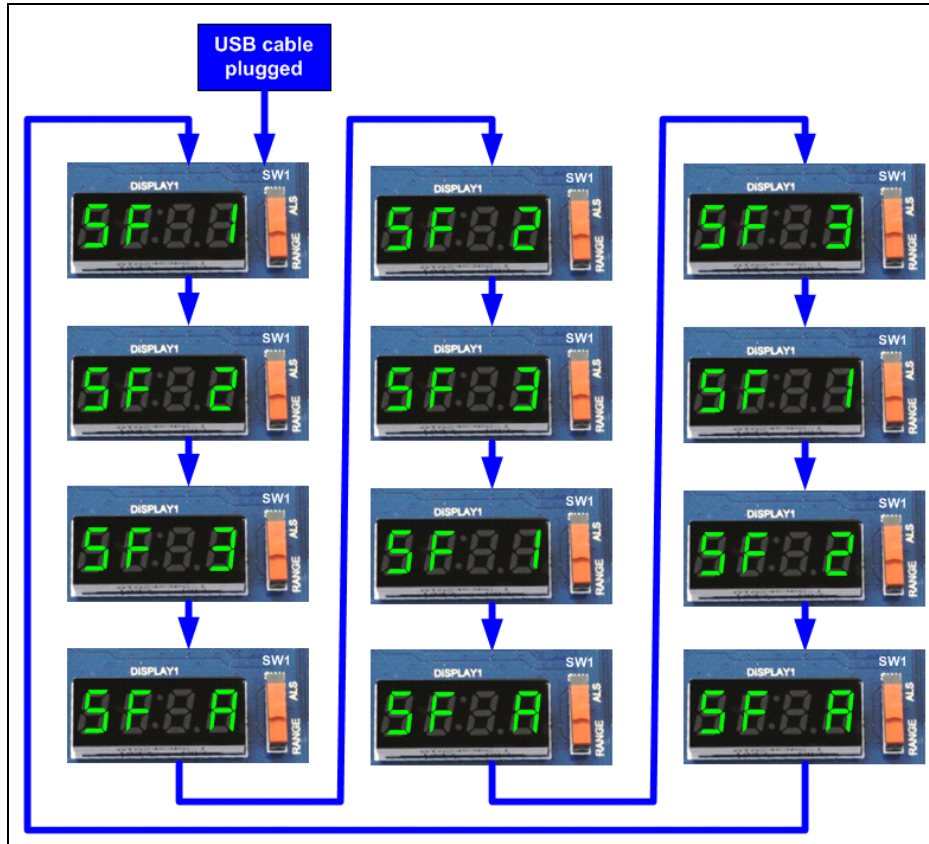

At any time the user can perform a long press on the blue button of the STM32 Nucleo board.

A long press on the blue button of the STM32 Nucleo board,



will activate the Alarm modes. For the duration of the button press the message “rb” (Release Button) will be displayed (see [Figure 19](#)) to indicate that the button must be released to proceed to the various alarm threshold modes provided.

Figure 19. rb message



When the blue button of the STM32 Nucleo board is released, the message “A-Lo” (“Alarm Low”) is displayed during few seconds (see [Figure 20](#)) to indicate the transition to the low range threshold mode.

This mode alerts the user to range measurements crossing below a pre-defined lower range threshold, it is set for this demonstration mode at 10cm. In a real application use case, the value of this threshold can be programmed through the VL6180X registers:

- Range measurements of targets above the threshold will result in the message “L” (see [Figure 21](#)).
- Range measurements of targets below the threshold will result in the message “L---” to indicate the alarm state (see [Figure 21](#)).

Figure 20. A-Lo message



Figure 21. L and L--- message

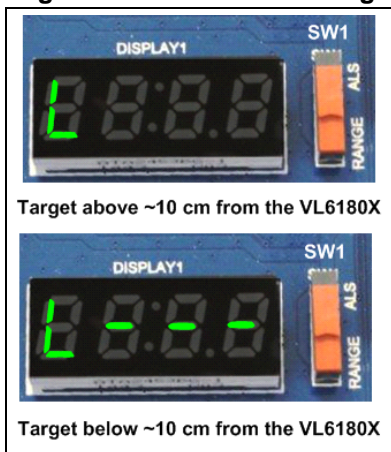

With the device in the “Alarm Low” mode, a subsequent short press



on the blue button of the STM32 Nucleo board will transition to the ‘Alarm High’ mode, resulting in the message “A-hi” being displayed for a short duration (see [Figure 22](#)).

This mode alerts the user to range measurements transgressing above a pre-defined upper range threshold, set for this demonstration mode at 25cm. In a real application use case, the value of this threshold can be programmed through VL6180X registers:

- Range measurements of targets above the threshold will result in the message “H” (see [Figure 23](#))
- Range measurements of targets above the threshold will result in the message “H--- “ to indicate the alarm state (see [Figure 23](#)).

Figure 22. A-hi message



Figure 23. H and H--- message

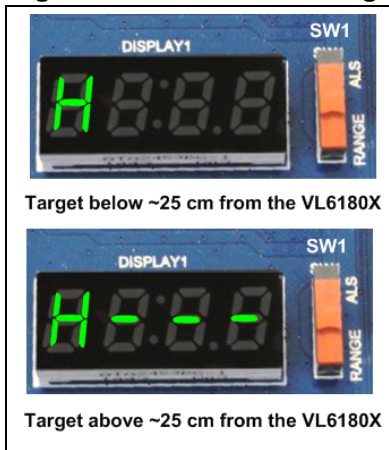

With the device in the 'Alarm High' mode, a subsequent short press



on the blue button will transition to the 'Dual Alarm' mode, resulting in the message "A-Oo" being displayed for a short duration (see [Figure 24](#)). Subsequently, moving targets may trigger up to two lower and upper range measurement thresholds.

If the target is below the pre-defined lower threshold (10cm), or above the pre-defined upper threshold (25cm), the message "O---" will be displayed to indicate the alarm state (see [Figure 25](#)).

Otherwise, if the target is within the upper and lower thresholds, the message "O" is displayed.

Figure 24. A-Oo message



Figure 25. O and O--- message

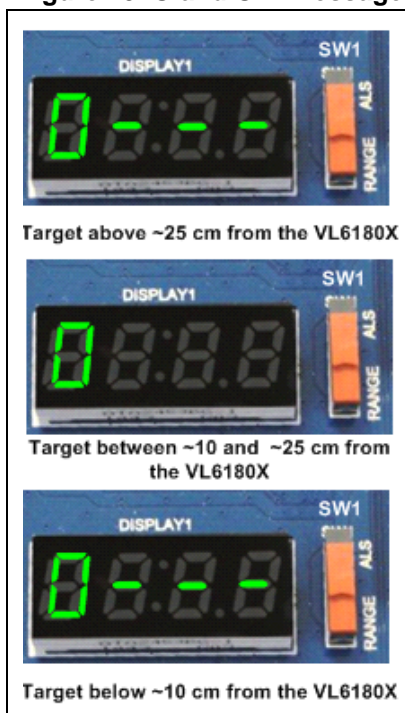

At next short press on the blue button of the STM32 Nucleo board, the user will return to “A-Lo” use case

A subsequent long press on the blue button of the STM32 Nucleo board will exit the alarm mode, the message “rb” is displayed for the duration of the press and, following release, the mode will exit “Alarm” and return to Ranging “SF-1”.

5.2.2 ALS mode

The switch SW1 must be in “ALS” mode:

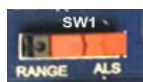

If the ambient light value is below 1000 Lux, the left digit of the display is as described in [Figure 26](#) and the three other digits give the Lux value.

Figure 26. Left digit of the display if ambient light value below 1000 Lux



If the ambient light value is above 1000 Lux, the left digit of the display is as described in [Figure 27](#) and the three other digits give the Lux value minus 1000 Lux. In this example the lux value is 1348 lux.

Figure 27. Left digit of the display if ambient light value above 1000 Lux



The VL6180X sensor is able to measure up to 10kLux, however this demonstration kit is limited to 1.8kLux.

5.3 “RangingWithSatellites” demonstration

- Drag and drop the “RangingWith Satellites_NucleoXXX.bin” file, which one you select will depend if you use a L053R8 or a F401RE or a L476RG STM32 Nucleo board.

Figure 28. VL6180X RangingWithSatellites demonstration installation - step 4

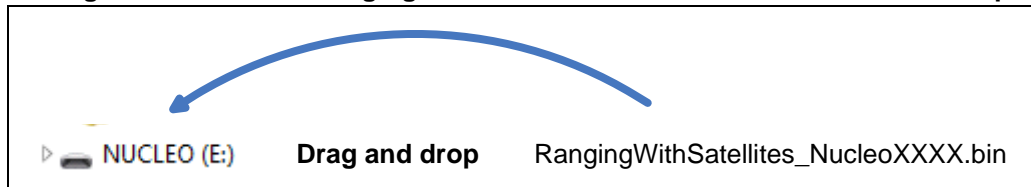
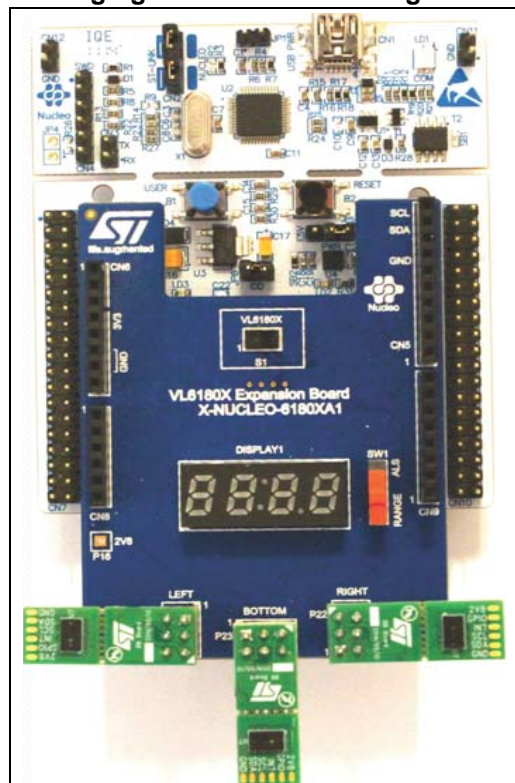
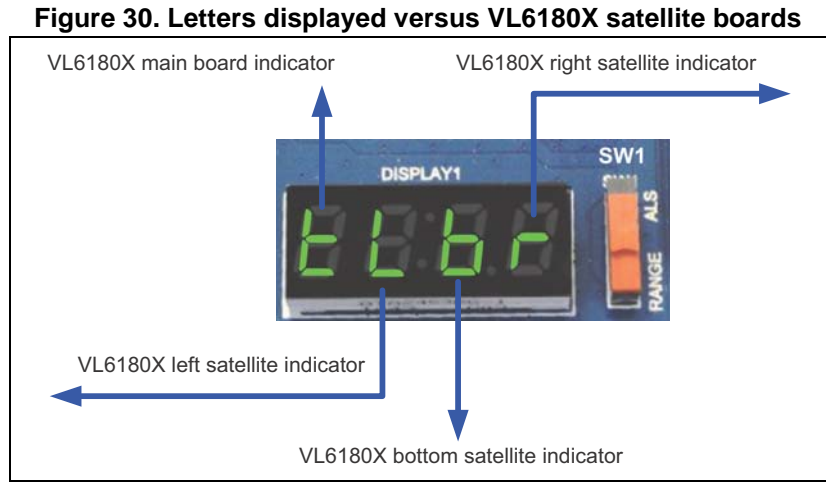

Figure 29. STM32 Nucleo, VL6180X expansion and VL6180X satellites boards - “RangingWithSatellites” configuration



The multiple VL6180X standalone demonstration is only for ranging.

When the USB cable is connected, the display shows below letters (see [Figure 30](#)).



Each digit letter indicates one of the four potential VL6180X devices in operation:

- “t”: VL6180X on the main board
- “L” VL6180X on the left satellite board
- “b” VL6180X on the bottom satellite board
- “r” VL6180X on the right satellite board

After a short press on the blue button of the STM32 Nucleo board,



horizontal bar segments are displayed on the LCD digits to indicate various ranging distances. Each digit corresponds to one of up to four VL6180X devices attached, as illustrated in [Figure 31](#):

- If the target is within short range of a VL6180X device, a single bar segment is displayed on its digit.
- When the target is in medium or long range of the VL6180x device, two and three bars are displayed, respectively, on the corresponding digit.

Once the target exceeds a pre-defined maximum limit the corresponding digit for the VL6180X device has an empty display.

Figure 31. Bar-graph displayed versus the distance between the target and the 4 VL6180X devices

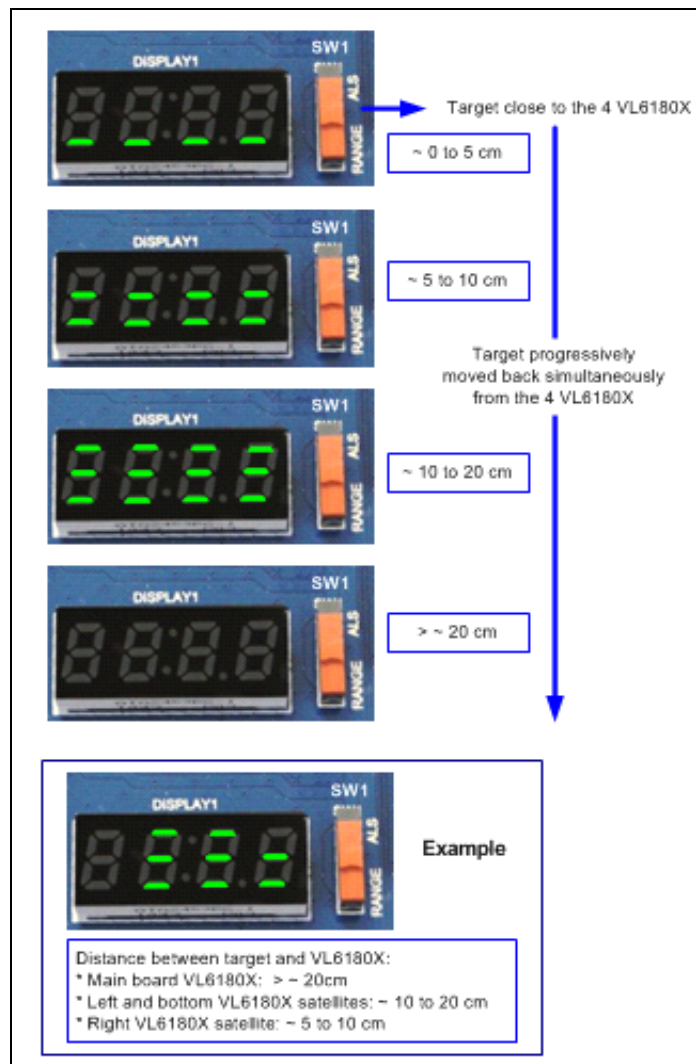

This demonstration can be used as a starting point for developing basic gesture recognition algorithms using several VL6180X devices.

5.4 “GestureDetect1” demonstration

- Drag and drop the “GestureDetect1_NucleoF401.bin” file, for this you have to use a F401RE STM32 Nucleo board.

Figure 32. VL6180X GestureDetect1 demonstration installation - step 4

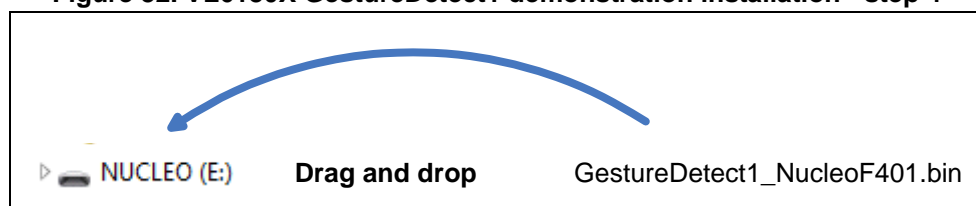
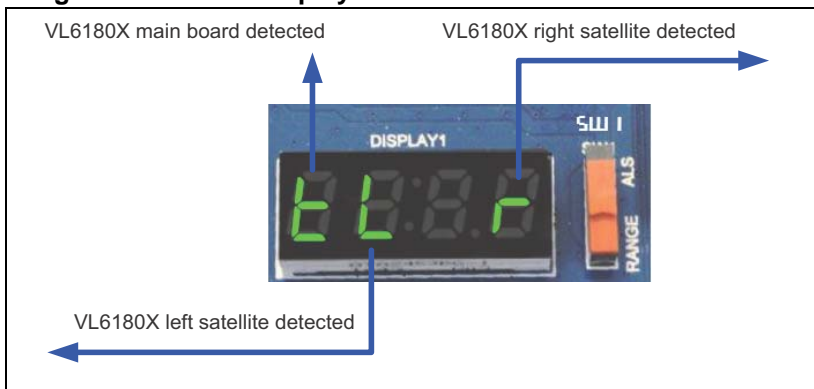

Figure 33. STM32 Nucleo, VL6180X expansion and two VL6180X satellites boards - "GestureDetect1" configuration



When the USB cable is connected, the display shows below letters (see [Figure 30](#)).

Figure 34. Letters displayed versus VL6180X satellite boards



Each digit letter indicates if the VL6180X is present or not:

- "t": VL6180X on the main board
- "L" VL6180X on the left satellite board
- "r" VL6180X on the right satellite board

The GestureDetect1 VL6180X standalone demonstration shows several features, range swipe and tap detections.

The following sections describe the ranging feature and the two gesture detection features, [Figure 35](#) shows how to switch from one feature to another.

Figure 35. "GestureDetect1" demonstration flow

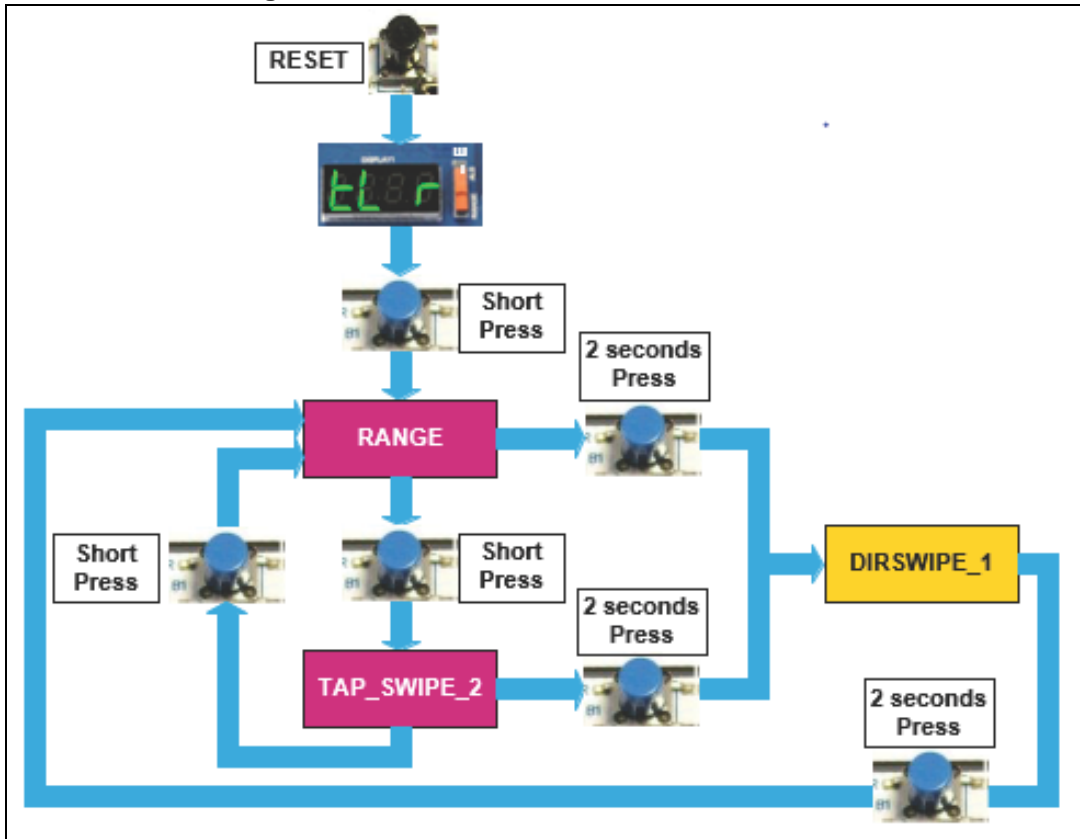

The switch SW1 must be in "RANGE" mode:



5.4.1 Ranging mode and single swipe / single tap (TAP_SWIPE_2) mode

In this mode only the VL6180X on the main board is used.

Ranging mode

With a short press on the blue button of the STM32 Nucleo board, the VL6180X goes in ranging mode.



- the message as shown in [Figure 36](#) is displayed if no target is present at a distance higher than 20cm from the VL6180X connected on the main board

Figure 36. Target above 20cm from the VL6180X on the main board



- the message as shown in [Figure 37](#) is displayed if a target is present at a distance lower than 20 cm from the VL6180X, the distance is displayed in mm (e.g.: 198mm).

Figure 37. Target below 20cm from the VL6180X on the main board



Indicates that the VL6180X is in ranging mode.

TAP_SWIPE_2: Single swipe / single tap mode

Another short press on the blue button of the STM32 Nucleo board, and the VL6180X goes into single swipe mode / single tap mode.



- Single swipe mode, if you move your hand from left to right or from right to left at a distance less than 20cm in front of the VL6180X on the main board the display changes as shown in [Figure 38](#).

Figure 38. Single swipe mode display

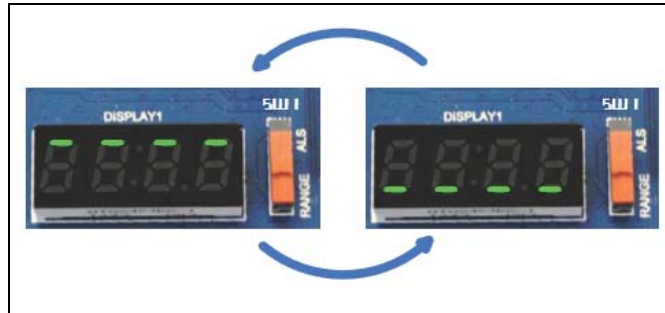

- Single Tap mode, if you move your hand up above the VL6180X on the main board, at a distance higher than 20cm and then take it down to a distance of less than 20cm, the display changes as shown in [Figure 39](#).

Figure 39. Single tap mode display

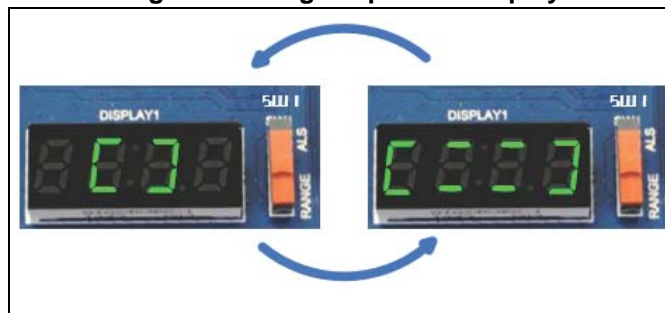

A short press on the blue button of the STM32 Nucleo board, and the VL6180X will go back to ranging mode.



5.4.2 Single directional swipe (DIRSWIPE_1) mode

In this mode the left and right VL6180X satellites are used.

From ranging mode or TAP_SWIPE_2 mode, press the blue button of the STM32 Nucleo board for 2seconds, the VL6180X will go into single directional swipe mode



While the blue button is pressed the message as shown in [Figure 40](#) is displayed.

Figure 40. Message during blue button is pressed



- When blue button is released VL6180X goes into the directional swipe mode, passing your hand over the VL6180X devices in a circular motion as shown in [Figure 41](#), [Figure 42](#) the message as shown in [Figure 41](#), [Figure 42](#) are successively displayed (to mimic book page turning).

Figure 41. Hand movement, circles to right

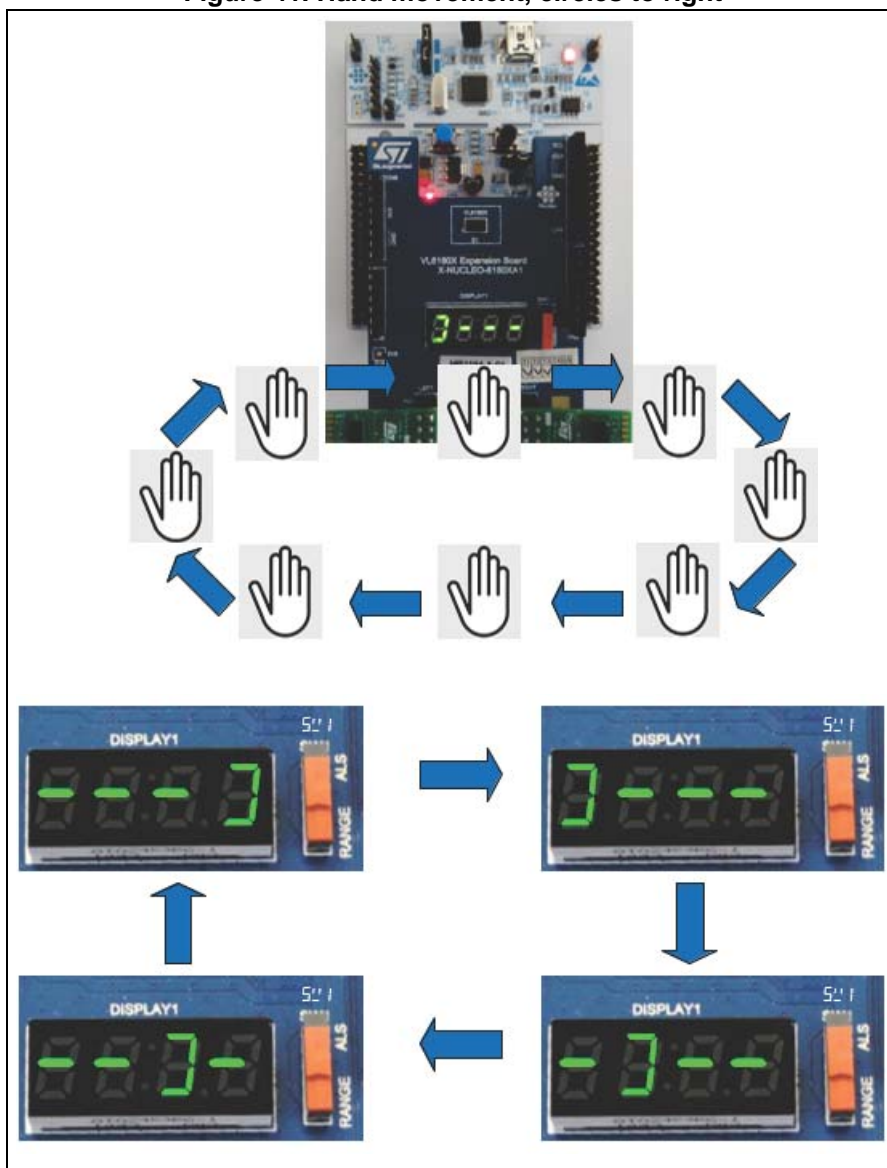
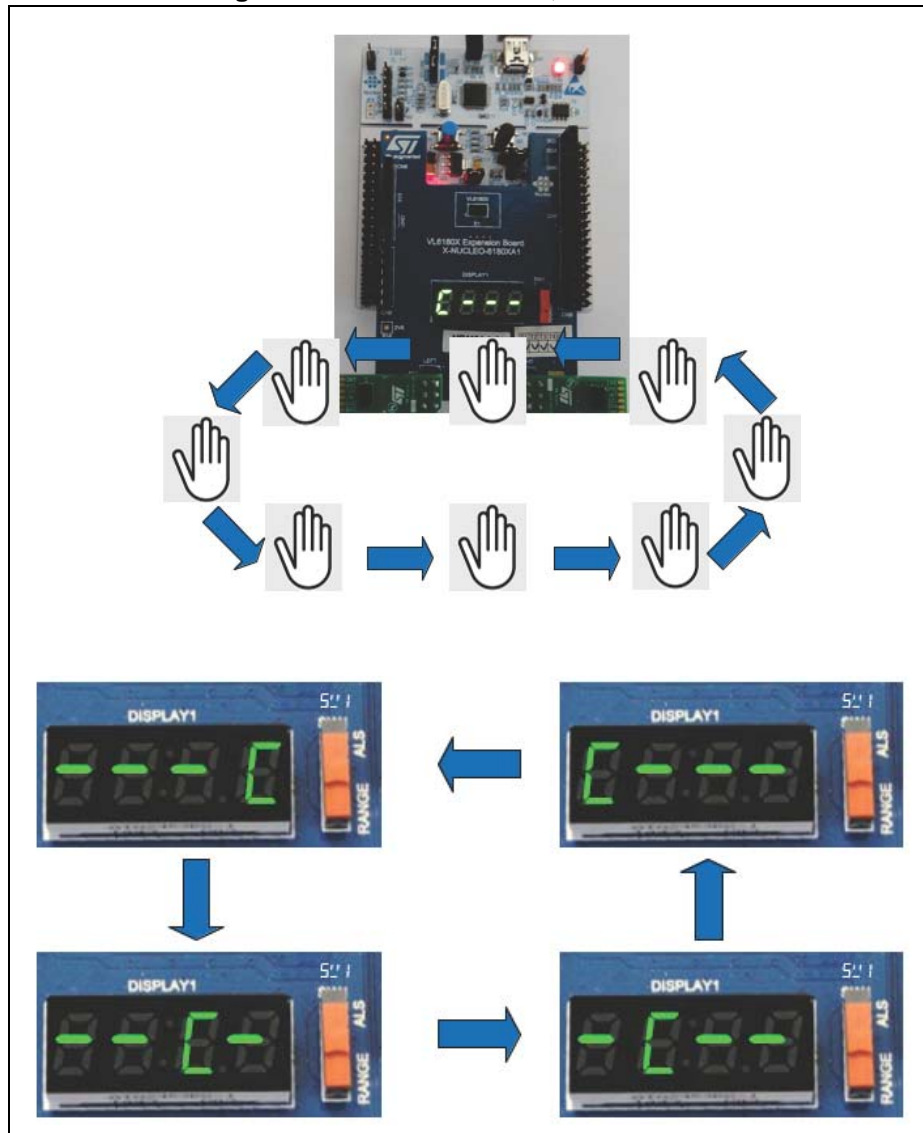

Figure 42. Hand movement, circles to left



A 2 second press on the blue button of the STM32 Nucleo board, the VL6180X goes back into ranging mode.



6 VL6180X software graphical user interface (GUI)

6.1 Installation of the VL6180X PC software graphical user interface (GUI)

The GUI shows, on the PC screen, the result of a range or an ALS measurement and allows the user to discover and test the different VL6180X settings.

Caution: As soon as the PC software runs, the VL6180X expansion board display is Off and values are only visible on the PC screen.

To install the PC graphical user interface:

- In P-NUCLEO-6180X1 or in P-NUCLEO-6180X2 web page select STSW-IMG004.

Figure 43. Installation of the VL6180X PC software GUI - step 1

Related Tools and Software	
Part Number	Description
STSW-LINK007	ST-LINK/V2-1 firmware upgrade
STSW-LINK009	ST-Link, ST-Link/V2, ST-Link/V2-1 USB driver signed for XP, Windows7, Windows8
X-CUBE-6180XA1	Proximity, gesture, ambient light sensor software expansion for STM32Cube
STSW-IMG004	Windows Graphical User Interface (GUI) for VL6180X Evaluation Kits. Works with P-NUCLEO-6180X1, P-NUCLEO-6180X2 and EVALKIT-VL6180X

- Click on "Download"

Figure 44. Installation of the VL6180X PC software GUI - step 2

Design Resources			
Product Specifications			
Description	Version	Size	
 DB2562: P-NUCLEO-6180X1 and P-NUCLEO-6180X2 packs PC graphical user interface (GUI)	2.0	84 KB	

Part Number	Version	Marketing Status	Order From ST
STSW-IMG004	r2359	Active	Download

(*) Suggested Resale Price per unit (USD) for BUDGETARY USE ONLY. For quotes, prices in local currency, please contact your local ST Sales Office or our Distributors
 (***) The Material Declaration forms available on st.com may be generic documents based on the most commonly used package within a package family. For this reason, they may not be 100% accurate for a specific device. Please contact our sales support for information on specific devices.

- Then "Save" and "Run" VL6180X_ExplorerSetup.exe, icon "VL6180X_Explorer" is installed on the user desktop space.

Figure 45. VL6180X_Explorer icon

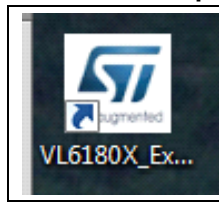

- Connect ST Nucleo pack to an USB PC port.
- Start PC graphic user interface by clicking “VL6180X_Explorer” icon.
- The **Ranging** tab is automatically selected.
- Click on the Start/Pause/Resume button to start the device (Start then when running “stop”) (see [Figure 46](#)).

Figure 46. Starting the device

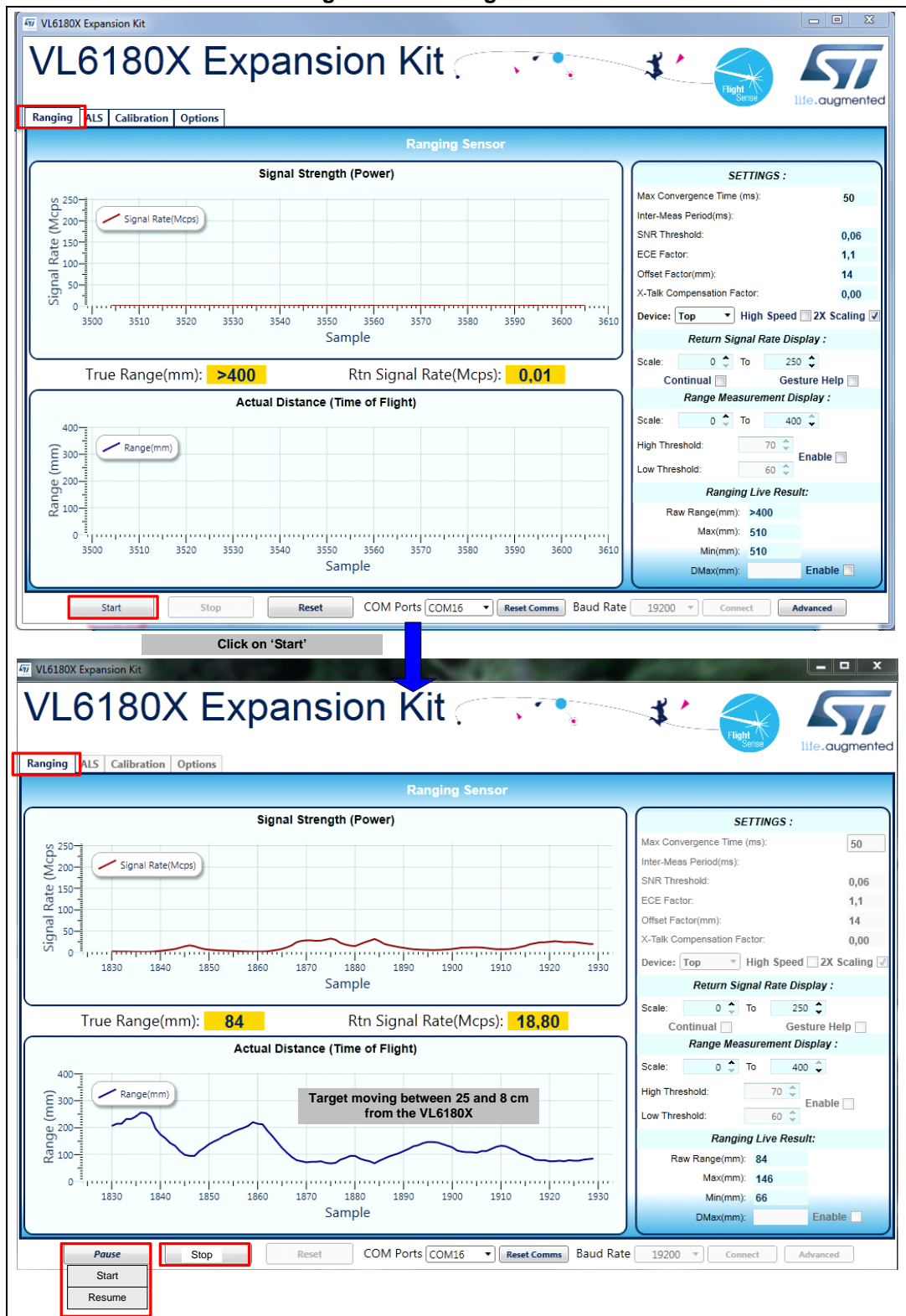

- Values are now displayed on the PC screen and not on the VL6180X expansion board display.

The VL6180X expansion board has one on-board device and up to 3 additional VL6180X satellite boards. Each sensor can be controlled individually from the GUI and can be selected using the 'Device' drop down control as follows (see [Figure 47](#)):

- Top : Default, On-Board device.
- Bottom : Bottom satellite device.
- Left : Left satellite device.
- Right : Right satellite device.

The VL6180X software GUI contains several tabs that can be used to display, calibrate and configure various features of the VL6180X. The available tabs are:

- **Ranging**, see [Section 6.2](#)
- **Calibration**, see [Section 6.3](#)
- **ALS**, see [Section 6.4](#)
- **Options**, see [Section 6.5](#)

6.2 Ranging tab

When the VL6180X expansion software is launched, the "**Ranging**" tab is displayed the ranging sensor interface as shown in [Figure 47](#).

In ranging mode, the VL6180X expansion board software measures absolute range from the sensor to a target. This is shown in graphical form in the two graphs displayed:

- **Signal Strength (Power)**, see [Section 6.2.1](#)
- **Actual Distance (Time of Flight - TOF)**, see [Section 6.2.2](#)

To use the software, place a target above the VL6180X device and click on **Start**. The device begins ranging and the **Signal Strength (Power)** and **Actual Distance (ToF)** graphs will display data in real-time and numerically in the settings and display boxes to the right.

Figure 47. Ranging tab

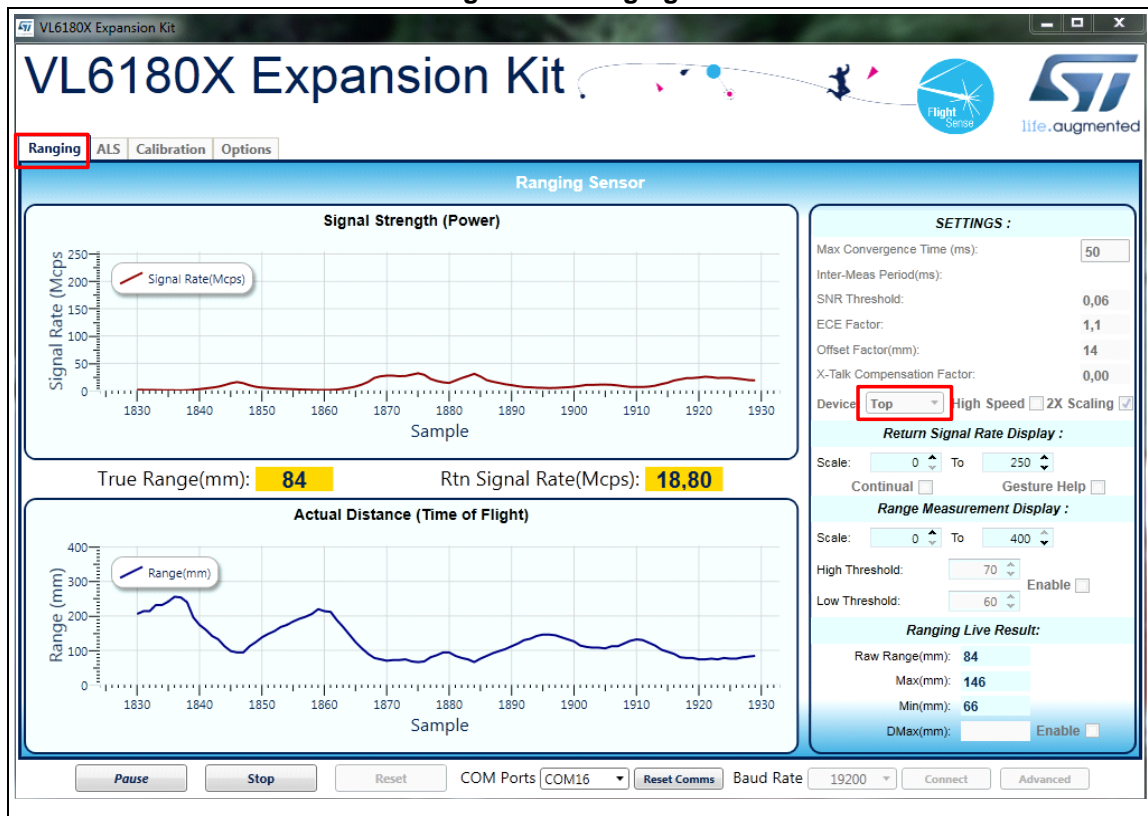

By default it is the VL6180X on the main board, called “Top” which is selected.

If satellites are connected, it is possible to select one of them, for this:

- Click on “Stop”, to stop the current measurement.

- Select one of the VL6180X devices.



- Click on “Start” to re-start the measurement.

The buttons listed in [Table 3](#) are available at the bottom of the **Ranging** tab.

Table 3. Buttons in the ranging tab

Button	Description
Start (Pause)	Click on Start to begin ranging. The Start button changes to Pause/Resume while the device is ranging.
Stop	Click on Stop to stop ranging.
Reset	The Reset button resets the I ² C communications interface between the application and the VL6180X.
COM Ports	The COM Ports box display a list of available connection ports to connect the VL6180X to the PC.

Table 3. Buttons in the ranging tab (continued)

Button	Description
Reset Comms	Resets the COM Port connection to the VL6180X software.
Baud Rate	Port COM speed (bits per second). Default is 19200.
Connect	Connects the chosen COM Port to the VL6180X expansion board software.
Advanced	To read and modify the content of a register.

6.2.1 Signal strength (power) graph

The **Signal strength (power)** graph plots, in real time, the Signal Rate (Mega Counts per Second) returned from the target, as shown in [Figure 48](#).

The Signal Rate can be viewed as a measure of the reflectance of the target, with high reflectance targets producing stronger signal rates.

Figure 48. Signal strength (power) graph

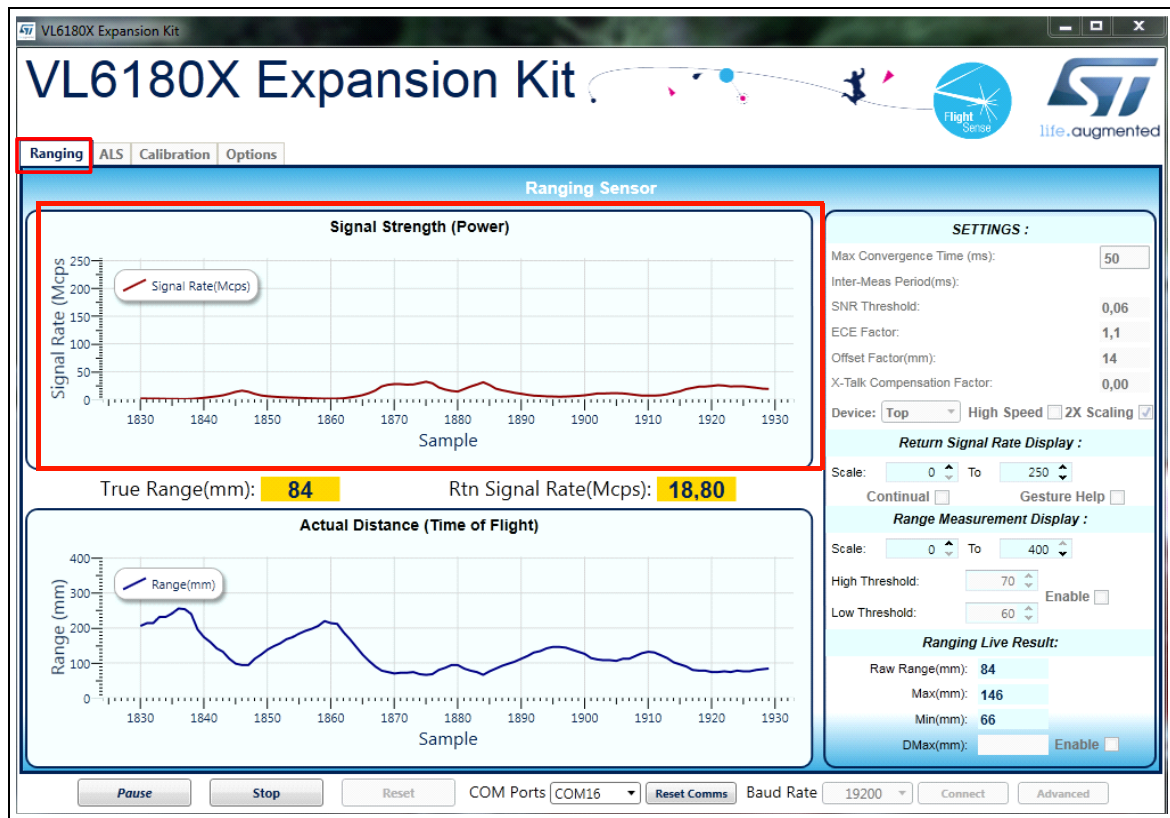

The settings and display information described in [Table 4](#) are indicated on the right of the **Signal strength (power)** graph.

Table 4. Signal strength (power) information

Field	Description
Max Convergence time (ms)	This is the maximum time allowed for a range measurement to be made. No range output is given if the system has not converged within the specified time (that is, no target or target out of range). Maximum convergence time default: for 1 x scaling = 30ms, and 50ms for 2 x scaling.
Inter Meas period (ms)	Inter measurement period is the time delay between measurements in continuous range mode. Range = 10ms to 2.55 seconds (default = 500ms). Only available if the 'Continual' ranging check box is ticked.
SNR threshold	The minimum SNR threshold below which a range measurement is rejected. The default value is 0.06.
ECE factor	The VL6180X has a built in Early Convergence Estimate feature. When enabled, the rate of convergence is automatically calculated 0.5ms after the start of each measurement. If the return count is below the ECE threshold the measurement is aborted. This minimizes power consumption and reduces red glow when there is no target. The ECE threshold is calculated as follows (example with ECE factor = 80%): ECE threshold = $(80\% \times 0.5 \times 15360) / \text{SYSRANGE_MAX_CONVERGENCE_TIME}$ (in ms)
Offset factor (mm)	This is fixed range offset parameter, which can be manually applied by the user to introduce a range adjustment.
X-Talk compensation factor	This parameter gets applied as part of the range measurement algorithm. It must be determined for each different air gap/glass using the calibration procedure. Parameter not set by default.
2X Scaling	Default setting: maximum range measurement up to 400mm (if box ticked), Maximum range can be approximatively 200 or 400mm ⁽¹⁾
Return Signal Rate Display	Manual adjustment of the Signal Rate vertical axis permissible range. Scale can be adjusted from 0...240 at the lower limit to 10...300 at the upper limit.
Continual	Changes ranging mode from single-shot to continuous mode.
Gesture Help	Provides some examples of gesture hand movements and signal comparison from a classical IR sensor with the VL6180X.

1. Under certain conditions, the VL6180X will detect targets above the specified 100mm. With the "2x Scaler" default setting, the maximum distance measurement can be up to 400 mm with a reported granularity of 2mm. For applications requiring a granularity of 1mm, scaling factor must be set to 1 and maximum distance measurement will be reported up to 200mm.

6.2.2 Actual distance (ToF) graph

The **Actual distance (ToF)** graph plots, in real time, range measurements (see [Figure 49](#)). The vertical axis can be changed using the **Range Measurement display** Scale. If a target is not detected, the maximum range is displayed.

Figure 49. Actual distance (ToF) graph

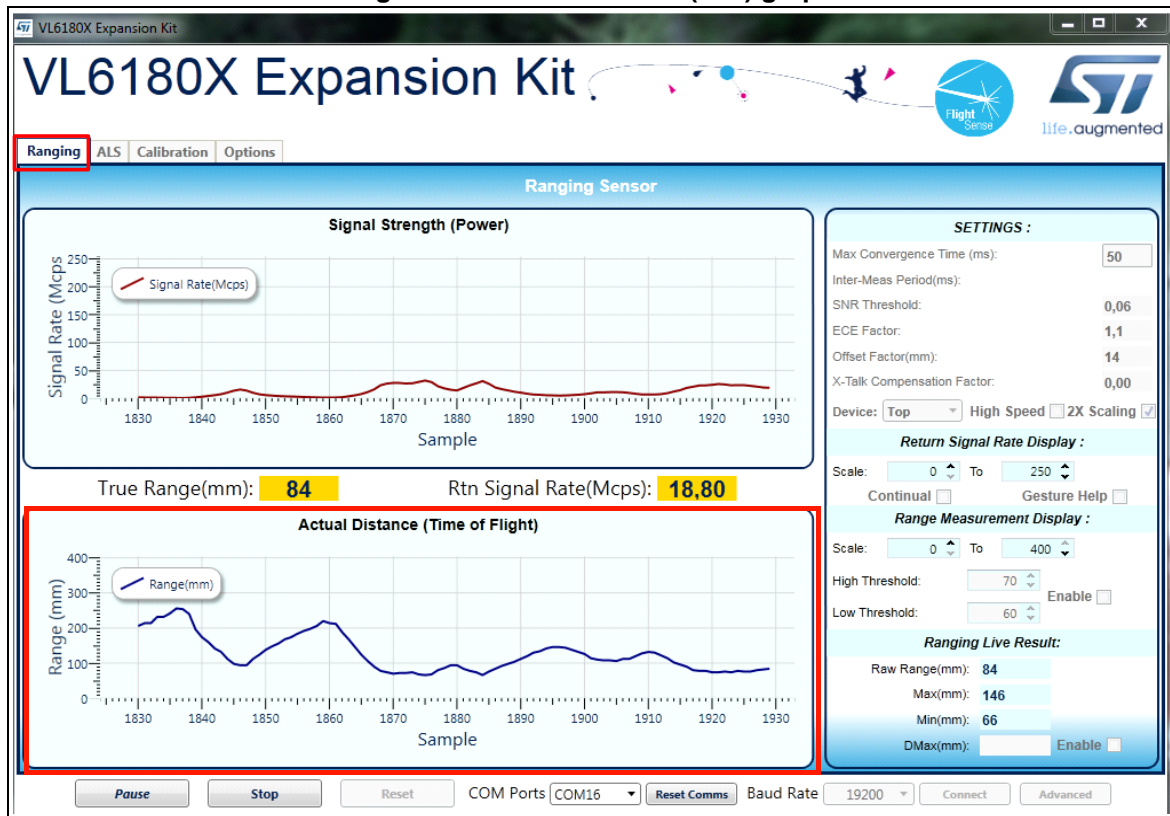

The VL6180X expansion board software can be run in single-shot ranging mode (default) or continuous ranging mode (by ticking the **Continual** check box to the right of the **Signal Strength (Power)** graph, see [Figure 48](#)). If in Continual ranging mode the time between measurements can be changed by adjusting the **Inter-Meas Period (ms)**.

The **Actual Distance (ToF)** graph can be changed to show threshold information, see [Section 6.2.3](#).

To the right of and above the **Actual Distance (ToF)** graph, the information described in [Table 5](#) is displayed.

Table 5. Actual distance (ToF) information

Field	Description
Range Measurement Display	Manual adjustment of the Range vertical axis permissible range. For 2 x scaling the scale can be adjusted from 0...390 at the lower limit to 10...400 at the upper limit. For 1 x scaling the scale can be adjusted from 0...190 at the lower limit and 10...200 at the upper limit
Enable	Check the Enable box to allow thresholding to be enabled.
Low Threshold	Manual adjustment of the lower threshold limit (default is 60mm). When enabled, this threshold line is shown in the Actual Distance (ToF) graph. See Section 6.2.3: Actual distance (ToF) graph showing thresholds .
High Threshold	Manual adjustment of the upper threshold limit (default is 70mm). When enabled, this threshold line is shown in the Actual Distance (ToF) graph. See Section 6.2.3: Actual distance (ToF) graph showing thresholds .
Raw Range (mm)	This is the range measurement including the Offset Factor.
Max & Min (mm)	These are post-processed measurement statistics to make noise evaluation easier to characterize. The max and min are the range data measured by the sensor over 100 measured sample points.
DMax (mm)	If enabled DMax is calculated by the software. This is the maximum measurement distance for a target of 17% reflectance under current configuration, see Section 6.2.5 .

6.2.3 Actual distance (ToF) graph showing thresholds

The thresholding feature allows the user to define upper and lower limits and be alerted as the range measurements transition across these limits by the display changing color.

Figure 50 shows examples of the **Actual Distance (ToF)** graph with high and low thresholding enabled. It shows a minimum threshold of 60 mm, a maximum threshold of 150 mm and range measurements above and below the thresholds.

If the range measurement goes below the lower threshold the graph turns green as shown in the top graph. If it goes above the upper threshold the graph turns pink as shown in the lower graph. The graph will stay pink/green, till the lower/upper threshold is crossed.

Thresholding is enabled by checking the **Enable** check box (see Table 5) and the upper and lower threshold settings can be modified in the **High & Low Threshold** settings.

Note: The upper and lower lines combine to effectively provide a binary threshold feature i.e. reporting when range measurements are above and below the lines. The two lines are equivalent to the hysteresis required to account for noise in the range measurements. A single threshold value would produce excessive flickering when the target was around the threshold value.

Figure 50. Actual distance graphs showing high and low thresholds



Color management

- Increasing range measurements crossing high threshold will cause a transition to the “red” state.
- Decreasing range measurements crossing low threshold will cause a transition to the “green” state.

6.2.4 Gesture help

When “Gesture Help” is selected a pop-up dialogue is displayed to illustrate how the VL6180X device can be used to detect two different gestures.

The combination of distance measurement and signal amplitude, both reported by the sensor, allows the VL6180X to interpret gestures and differentiate vertical gesture from horizontal swipe.

Vertical Gesture

A vertical hand movement, up-down then back-up will cause the signal amplitude to increase then decrease, whereas the range measurement will report the opposite.

Horizontal Swipe

A horizontal ‘Swipe’ movement will cause the signal amplitude to increase while the hand enters the field of view of the sensor and then reaches the center of the field of view, and then decrease as the hand moves away. At the same time, the range measurement will remain constant while the hand is moving horizontally above the sensor.

Figure 51. Gesture help

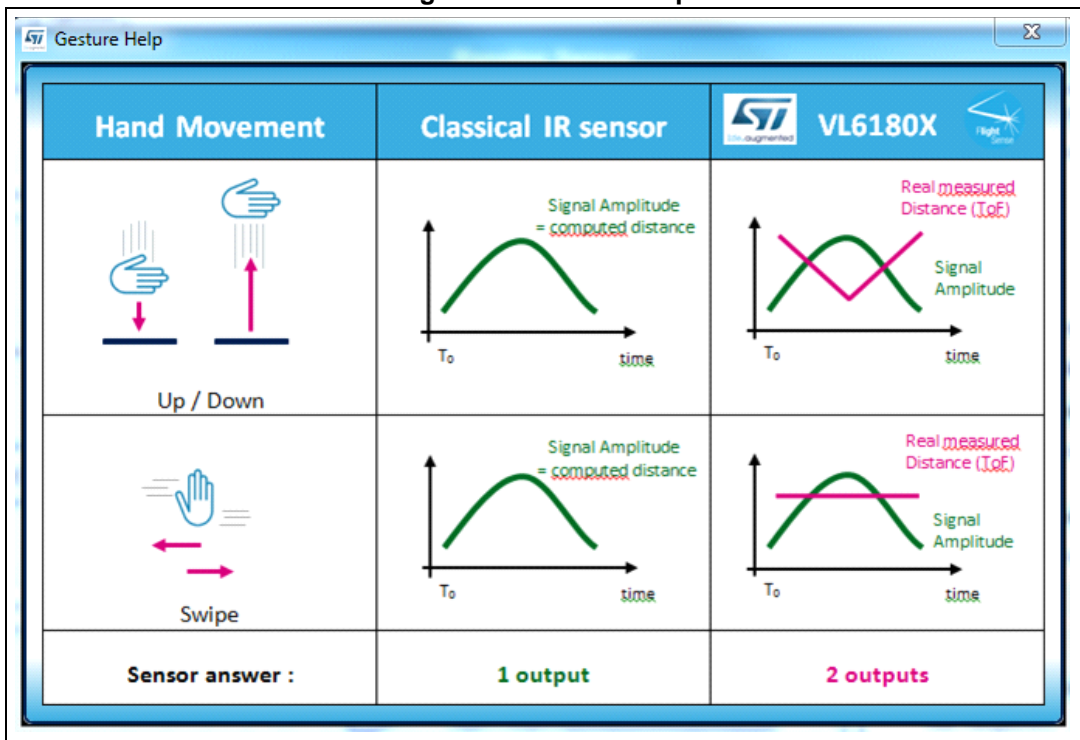

6.2.5 Dmax

DMAX reports the maximum ranging distance (mm) estimated by the VL6180X, for a target of 17% reflectance, taking into consideration the maximum convergence time and cross-talk compensation settings, and the ambient light level.

DMAX can be selected or disabled, when in the Idle state (not ranging) by clicking on the 'Enable' checkbox.

Figure 52. Dmax feature

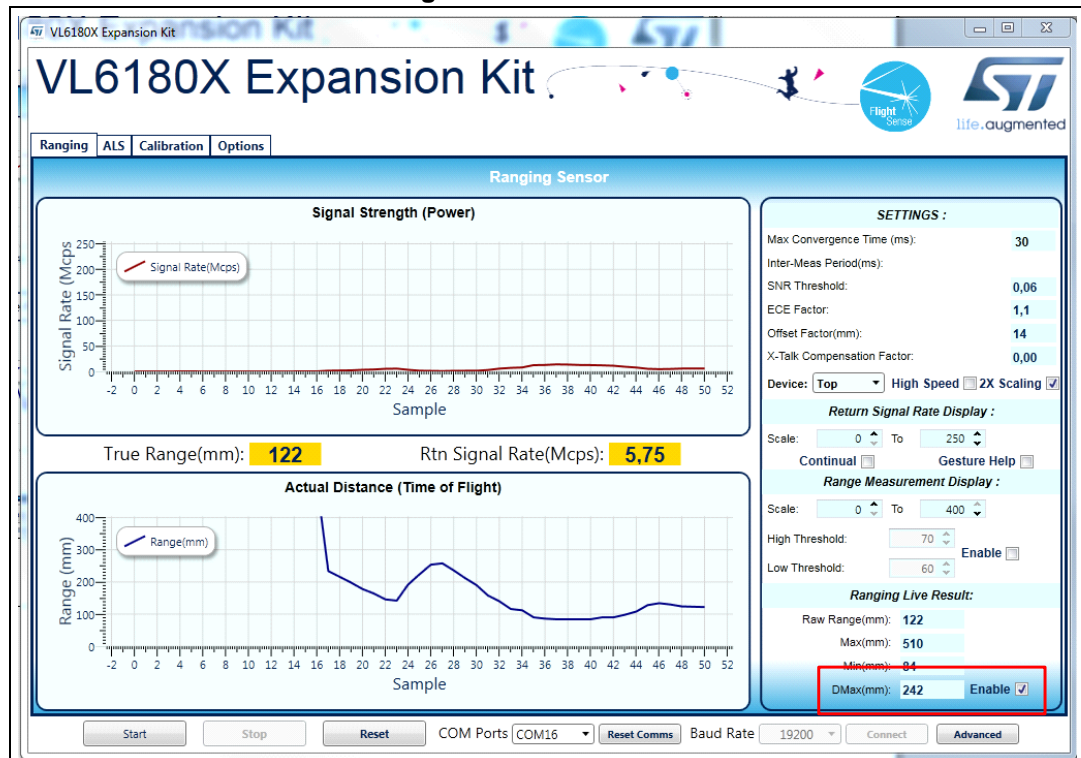

6.2.6 High speed

When high speed mode is selected the VL6180X control is not done by the PC but by the STM32, this allows a faster I2C communication, the drawback of the high speed mode is the DMAX value is not reported to the PC.

6.3 Calibration tab

The **calibration** tab of the GUI is not used with P-NUCLEO-6180X(i) pack but could be used to calibrate a final customer product in which a glass is used above the VL6180X. In this last case, in order to get accurate readings, the user may be required to calibrate the VL6180X range offset and the cross-talk compensation factor. This is carried out in the **Calibration** tab.

6.3.1 Offset calibration procedure with P-NUCLEO-6180X(i)

An offset calibration is performed for each VL6180X module during the final test of the manufacturing process, and stored into the NVM. So, the ranging measurement reported by

the product should be very close to the actual distance between a target and the VL6180X module. Despite this offset calibration, you may notice a remaining offset due to the soldering of the VL6180X module onto the expansion board. In this case, the VL6180X evaluation pack provides you with the possibility to make a manual offset calibration

The calibration procedure described below is efficient but will not deliver the highest precision.

- Put the jacket delivered with the VL6180X expansion board, or a grey paper, horizontally on the 4 digit display and above the VL6180X: this corresponds to the distance of 8 mm between the target and the top of the VL6180X.
- To have a precise measurement, set the max value of the “range measurement display” to 10. (see [Figure 53](#))
- Check the value of “Raw Range”, if the “Raw range” does not equal to 8mm then the “offset factor” value must be modified.
- In the following example, before manual offset calibration, the “offset factor” reports a 14 mm offset factory calibration value, (see [Figure 53](#)), while the actual distance of the target is measured at 6mm. The “offset factor” must be adjusted from 14 to 16mm, increasing the raw range of 2mm to reach the value of 8mm after offset calibration (see [Figure 54](#)).

Note: Each time you modify the “offset factor” you have to do a “stop” “start” button sequence. Each time the P-NUCLEO-6180X(i) is switched-off, the “offset factor” value is cleared back to the factory calibration, so, if previously manually modified, the “offset factor” must be reloaded at the next switch-on of the P-NUCLEO-6180X(i).

Figure 53. Before offset calibration procedure

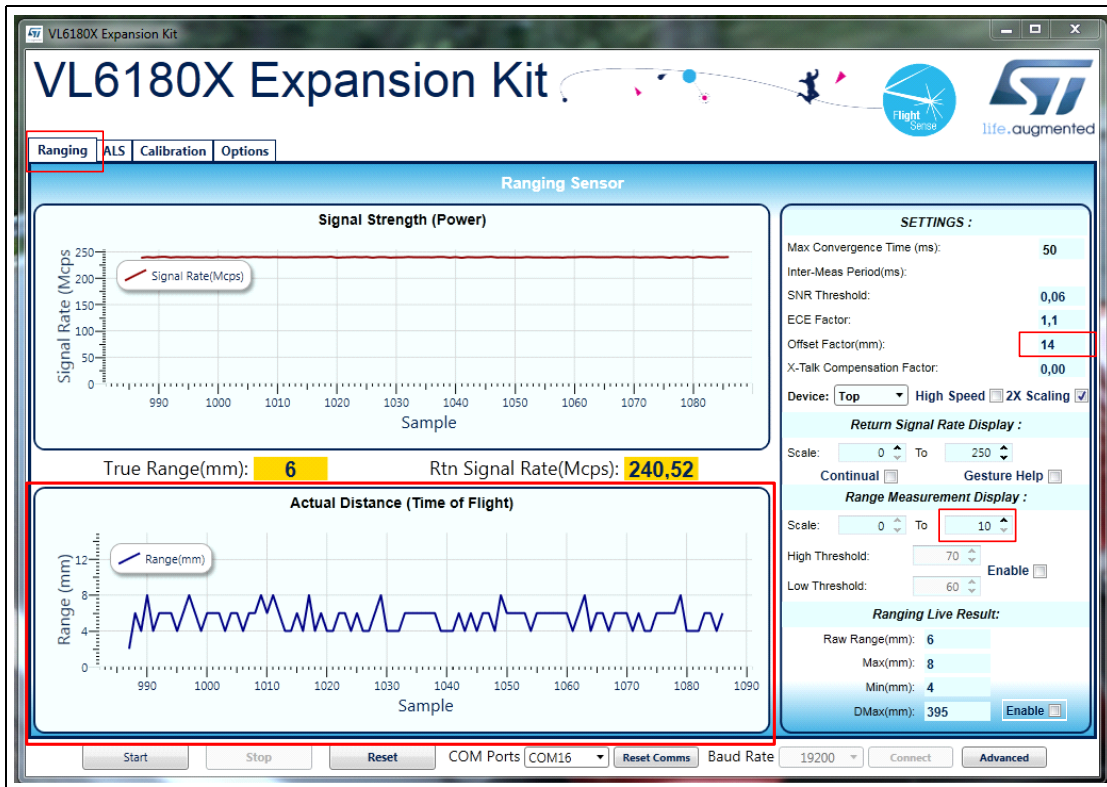
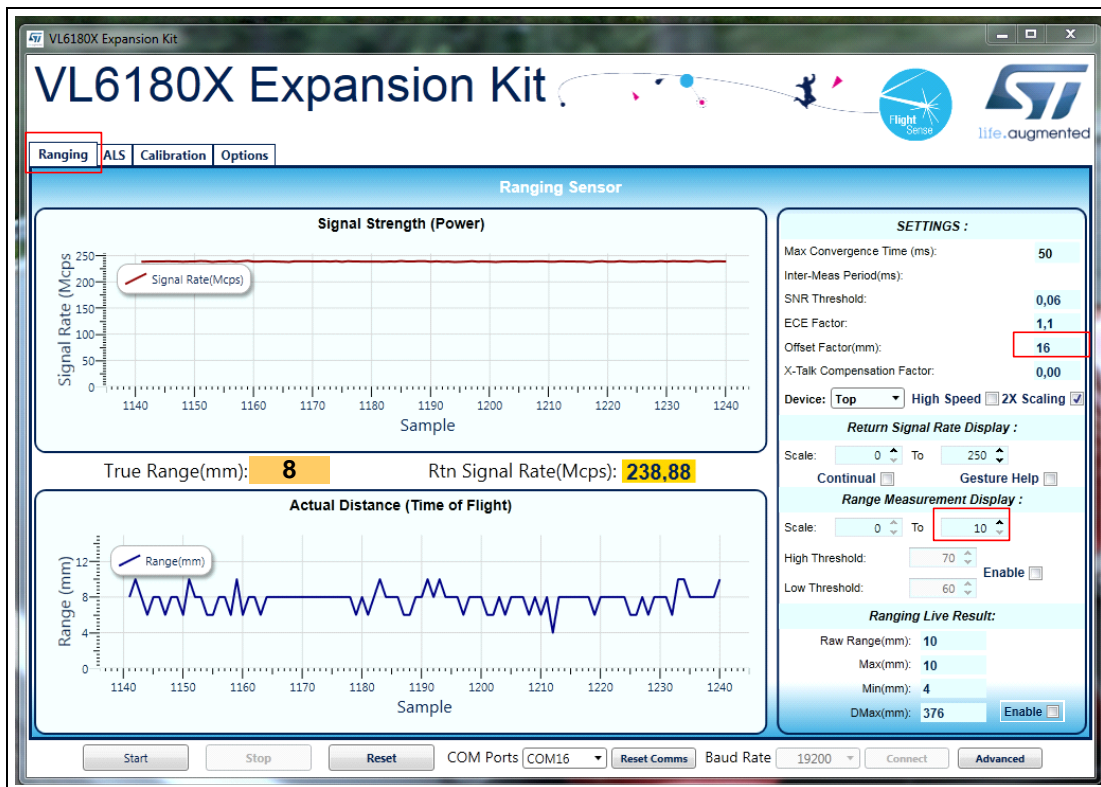

Figure 54. After Offset calibration procedure



6.3.2 VL6180X offset and cross-talk calibration in a final product

In case the user replaces the VL6180X module by their own module with glass above VL6180X module, ST offers the possibility to calibrate its product using the **Calibration** tab of the GUI.

Note: To move from the **Ranging** tab to the **Calibration** tab, the VL6180X must stop ranging.

Calibrating the range offset

The VL6180X device requires a unique part-to-part range offset correction. The default programmed value may be correct, however it may be required for the user to override this and apply a different setting.

The range offset (offset factor) is calibrated using a white target, at least 60 x 60 mm square, placed 50 mm above the sensor.

The resultant offset is added to the raw range: $R_0 = R_r + \text{offset}$, where R_0 is the offset range and R_r is the raw range in mm, see [Figure 55](#).

If there is a glass in front of the VL6180X device a unique cross-talk compensation factor must be determined and applied. If the glass configuration is altered in any manner, a new cross-talk compensation factor must be determined.

Figure 55. Range offset

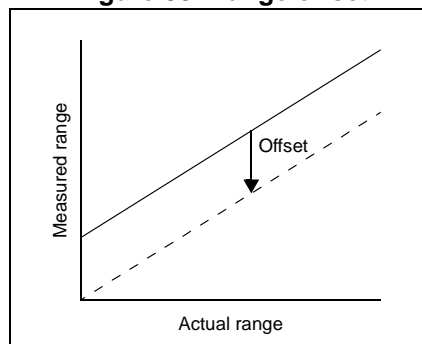

The factory calibrated NVM offset is used by default. Manual calibration is only required if the offset is incorrect, resulting in incorrect range measurements.

To activate the automatic offset calibration (see [Figure 56](#)) select the **Calibration** tab and follow the instructions.

Figure 56. Range offset calibration

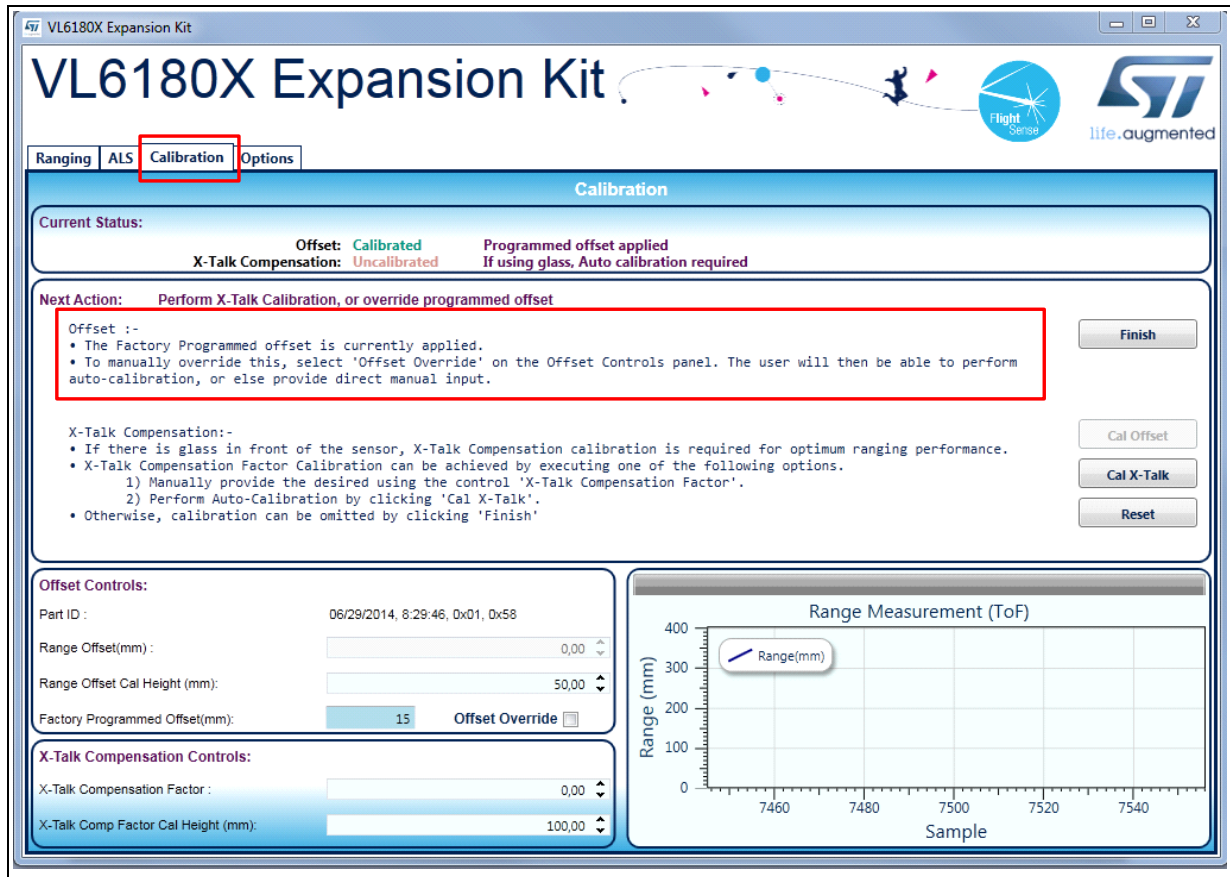

Calibrating cross-talk compensation factor

The glass in front of the VL6180X device introduces stray light, also known as cross-talk, where a proportion of the emitter output is reflected back to the receiver. This distorts the range measurement but can be corrected by applying cross-talk compensation.

If there is glass in front of the VL6180X device a unique cross-talk compensation factor must be determined and applied. If the glass configuration is altered in any manner, a new cross-talk compensation factor must be determined.

Figure 57. cross-talk compensation factor

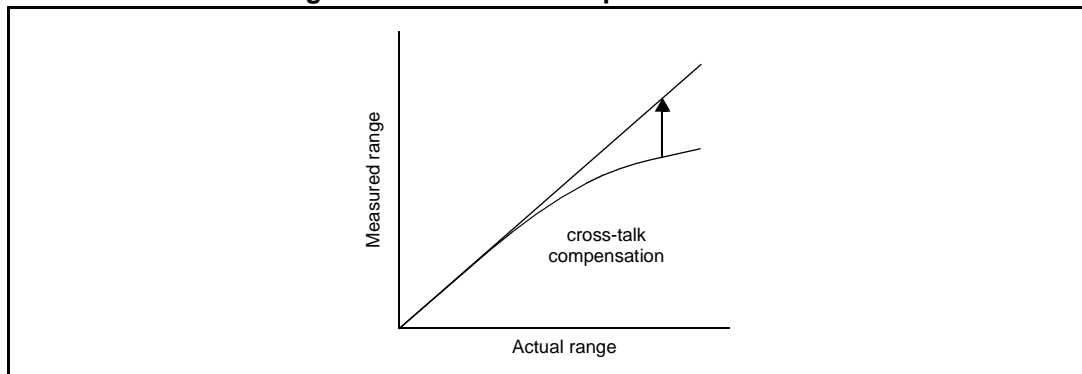

The cross-talk compensation factor (x-talk) is calibrated using a target of approximately 3% (black) reflectance, at least 60 x 60 mm square, placed 100 mm above the sensor.

To activate automatic x-talk calibration, select the **Calibration** tab and follow the instructions (see [Figure 58](#)).

Figure 58. Cross x-talk compensation factor.

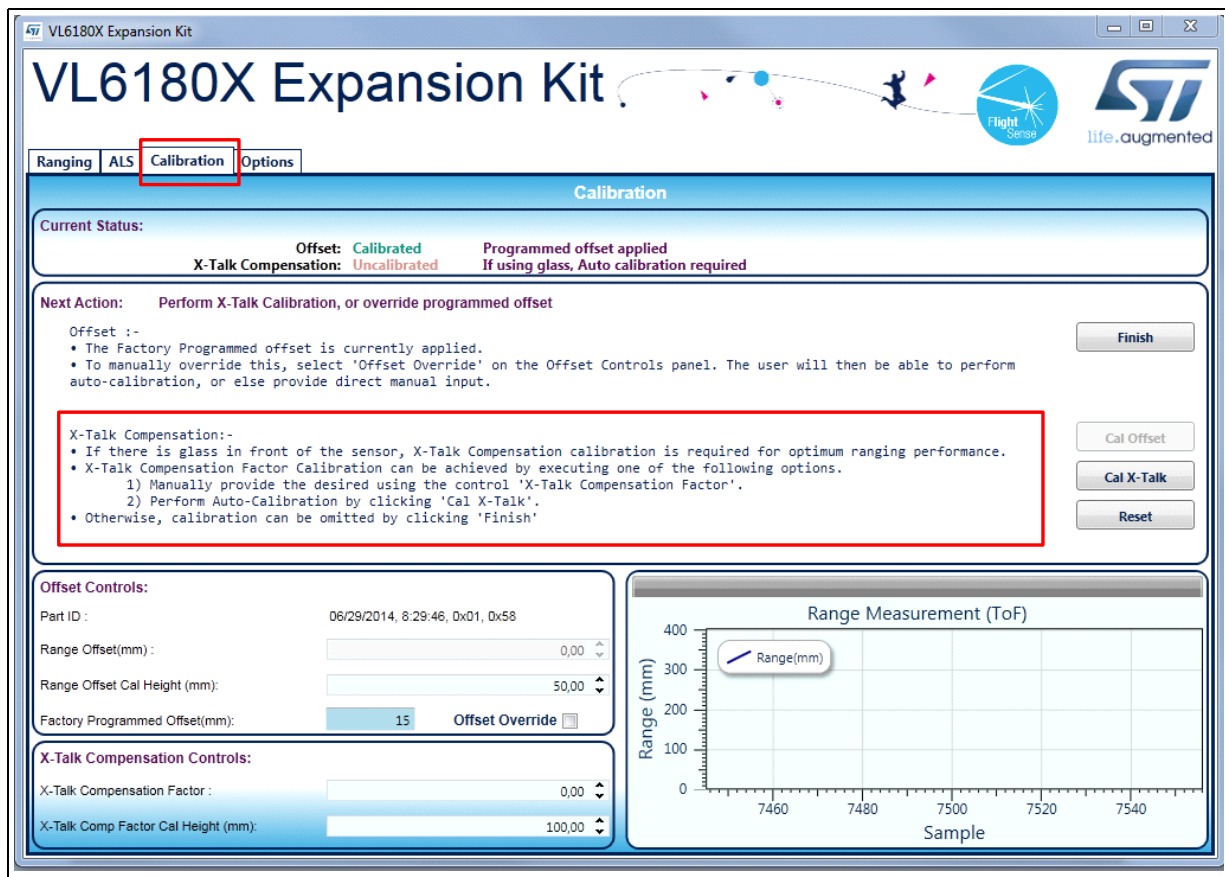

When offset calibration and x-talk compensation are ended, the new values of both parameters are automatically reported in the **Ranging** tab in the "SETTINGS" windows and in the fields:

- "Offset factor (mm):"
- "X-Talk Compensation factor:"

6.4 Ambient light sensor (ALS) tab

The ambient light sensor can be activated in the **ALS** tab. This tab displays the **ALS Count** graph showing ALS Lux/count versus Samples, as shown in *Figure 59*.

Table 6 lists the buttons available in the ALS tab.

Figure 59. ALS tab

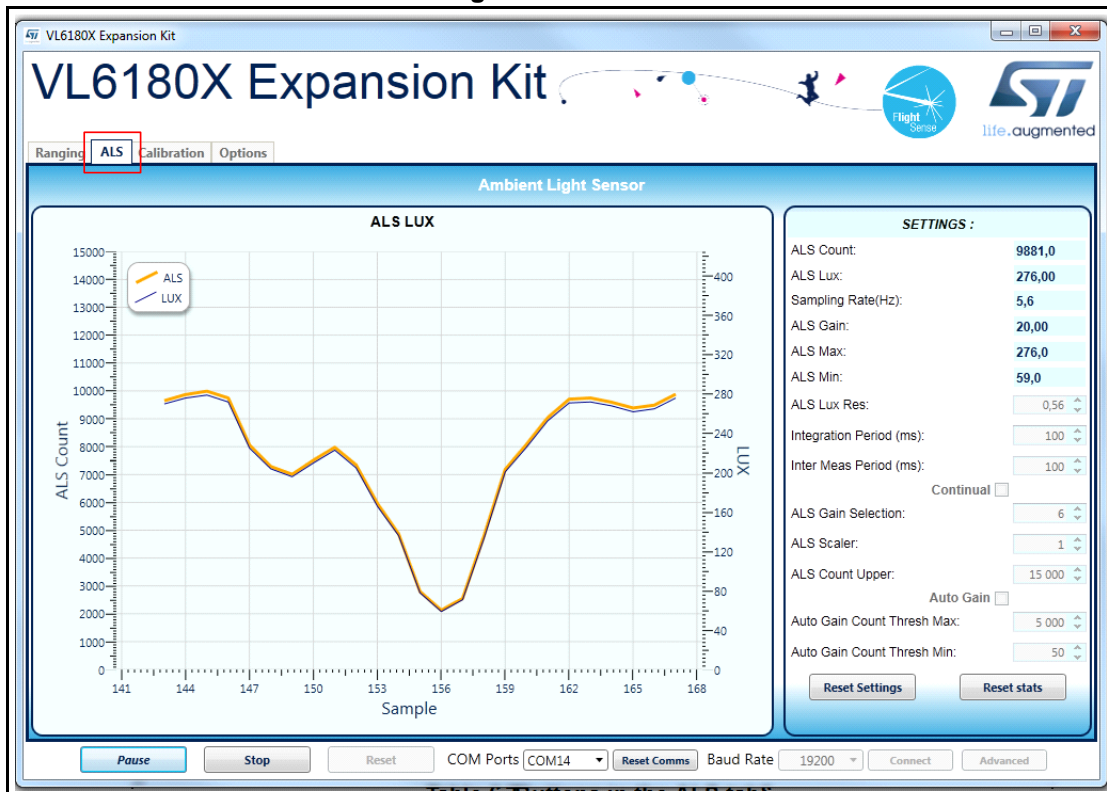

Table 6. Buttons in the ALS tab

Button	Description
Start (Pause/Resume)	Click on Start to begin measuring the ALS count. The Start button then changes to Pause/Resume .
Stop	Click on Stop to stop measuring the ALS count.
Reset	The Reset button resets the I ² C communications interface between the application and the VL6180X.
COM Ports	The COM Ports list shows available device ports.
Reset Comms	The Reset Comms button resets the comms between the device and the software.
Baud Rate	Port COM speed (bits per second). Default is 19200.

The information described in *Table 7* is displayed on the right of the **ALS** graph.

Table 7. ALS information

Field	Description
ALS Count	This is the raw output from the ambient light sensor. The count is proportional to the light level. The count output is a 16-bit binary value.
ALS Lux	The ALS Count value is converted automatically to a Lux value depending on the ALS Lux Res , ALS Gain , Integration Period and ALS Scaler settings.
Sampling Rate (Hz)	The number of ALS samples measured per second (PC dependent).
ALS Gain	Displays the actual gain value applied. This is set by the ALS Gain Selection setting.
ALS Max &Min	These are post-processed measurement statistics to make noise evaluation easier to characterize. The max, min and mean are the ALS data measured by the sensor over 100 sample points.
ALS Lux Res	This calibrates the ALS Lux/count conversion. The characterized ALS Lux Res is 0.56 (default).
Integration Period (ms)	The integration period is the time range, during a single ALS measurement, over which Lux data is captured and averaged. The default integration period is 100 ms.
Inter Meas Period (ms)	The inter-measurement period is the time between each ALS measurement in continuous ALS mode. The default inter-measurement period is 100 ms.
Continual	Changes ALS mode from single-shot to continuous mode.
ALS Gain Selection	This is the device register setting 0 to 7. The corresponding gain value is displayed in the ALS Gain box. Gain settings are as follows: 0: ALS Gain = 1 1: ALS Gain = 1.25 2: ALS Gain = 1.67 3: ALS Gain = 2.5 4: ALS Gain = 5 5: ALS Gain = 10 6: ALS Gain = 20 7: ALS Gain = 40
ALS Scaler	The count output is a 16-bit value. Internally, the device uses a 20-bit counter. Gain and integration time are normally used to increase sensitivity. However, if this is not sufficient and more resolution is required in low light, the ALS scaler can be used to access the 4 LSBs of the internal counter. Apply a value in the range 2 to 15 to apply additional gain.
ALS Count Upper	This is the maximum scale value for the vertical axis. The default value is 15000. The user can input a new value to scale the ALS Count graph up or down as required for measurements, up to a maximum value of 65,000.
Auto Gain	Enables and disables the auto-gain feature. Auto-gain automatically adjusts the gain selection in response to the current ALS Count value in order to provide an effective dynamic range for the current lighting conditions.

Table 7. ALS information (continued)

Field	Description
Auto Gain Count Thresh Min	The manual Auto Gain ALS count threshold minimum value in Auto Gain mode.
Auto Gain Count Thresh Max	The manual Auto Gain ALS count threshold maximum value in Auto Gain mode.

6.5 Options tab

The **Options** tab is used to enable I2C logging or data logging during ranging and ALS modes.

6.5.1 Data Logs options window

For every measurement, relevant system data is stored in a comma separated value file (.csv) identified by date and time.

To enable data logging, in the **Options** tab, check the **Enable Data Log** box, see [Figure 60](#).

Data logging should be selected either prior to starting measurements or during the paused state.

Figure 60. Enable data logging

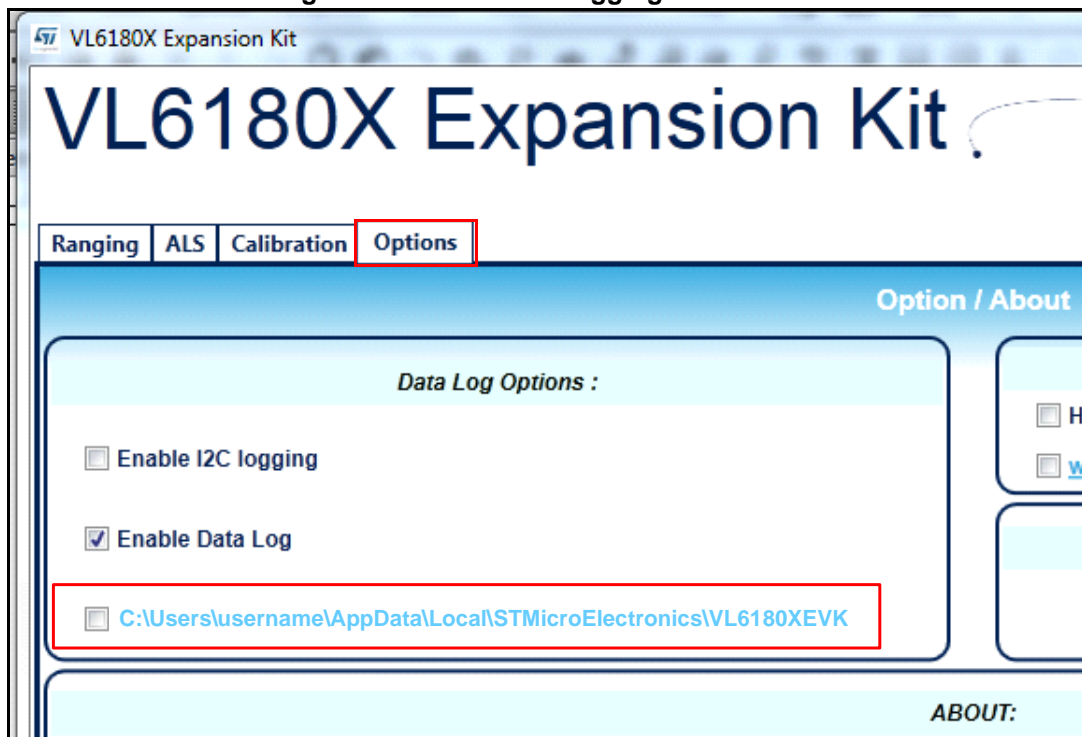

Data log files are created with unique filenames and stored in:
 C...\Users\username\AppData\Local\STMicroElectronics\VL6180XEVK\DataLog\
 See [Figure 60](#) and [6.6: Data log file](#) for an example.

Before you can switch off data logging, the device must first stop ranging or ALS measurements. To do this, click on the **Stop** button in the **Ranging** tab, see [Section 6.2: Ranging tab](#).

Recording I²C transactions

The **Enable I²C Logging** option is used to record I²C transactions during ranging or ALS mode. The I²C transactions are stored in a unique file (.txt) identified by date and time.

To enable I²C logging, in the **Options** tab, check the **Enable I²C Logging** box, see [Figure 61](#).

I²C log files are stored in:

C:\Users\username\AppData\Local\STMicroElectronics\VL6180XEVK\I2C\.

See [6.7: I²C log file](#) for an example.

Before you can switch off I²C logging, the device must first stop ranging or ALS measurements. To do this, click on the **Stop** button in the **Ranging** tab, see [Section 6.2](#).

Figure 61. Enable I²C logging

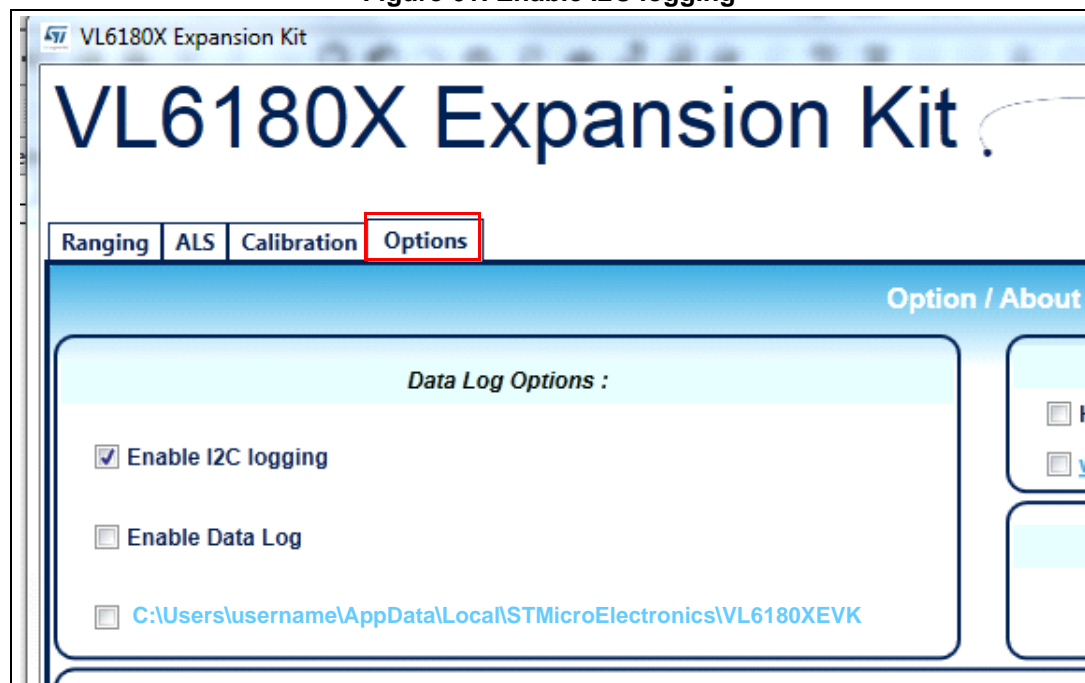

6.5.2 Help window

The **Help** provides links to documents and on line resources which provide details on the setup and functionalities of the VL6180X expansion board software and also details on the software version:

- **HELP:** To access help index
- www.st.com/VL6180X: To access ST VL6180X product and support page

6.5.3 About window

About GUI Version: Provides the GUI version installed

Figure 62. Help and about windows

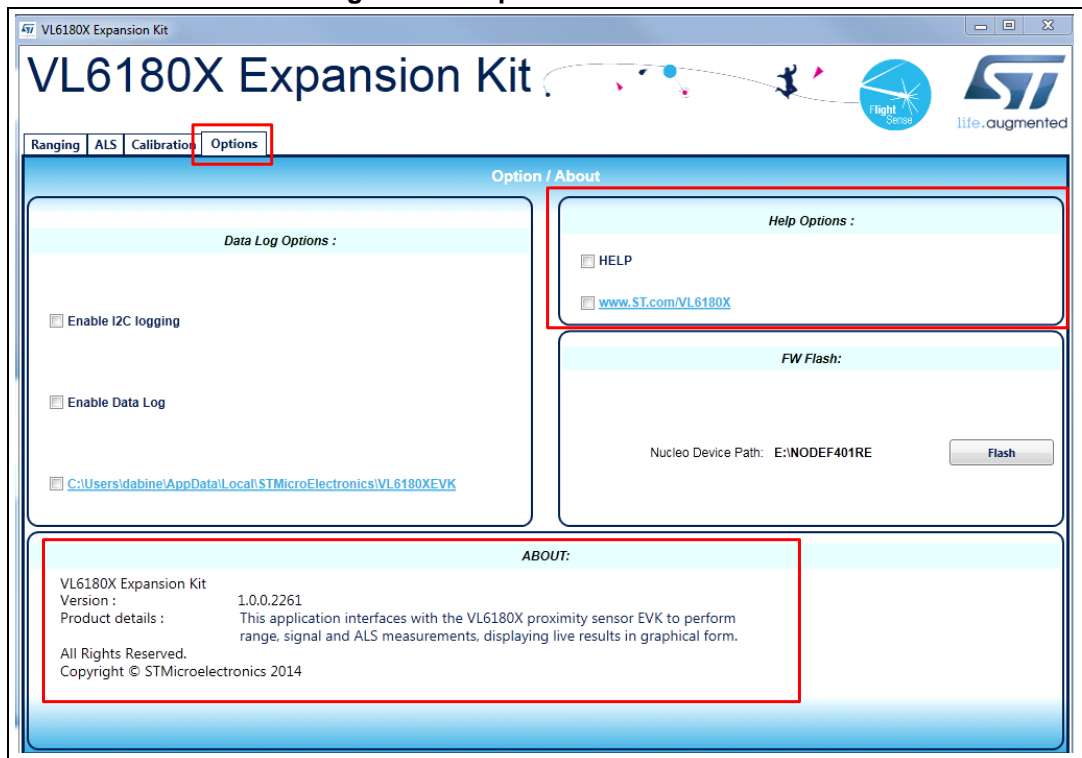

6.6 Data log file

Each data log is stored in a uniquely named .csv file. The data log filename configuration is data_log_DD_MMM_YYYY_HHMM_SS_sss.csv.

Where:

- DD_MMM_YYYY is the date the log file was created, for example 17_Apr_2014
- HHMM is the time (hours, minutes) the log file was created, for example 1025
- SS_sss is the time (seconds, milliseconds) the log file was created, for example 17_367.

An example of a ranging data log is shown in [Figure 63](#)

Figure 63. Data log file example

	A	B	C	D	E	F	G	H	I	J	K	L	
1	TimeStamp	Range Ext	Range Va	True Rang	True Rang	Raw Rang	Max Rang	Min Rang	Mean Rang	Range Str	Filter Size	Rtn Signa	Ref
2	14.129	143	115	115	115	115	115	115	115	0	500	12.14	
3	14.268	136	97	97	115	97	115	115	106	12.73	500	15.55	
4	14.408	139	78	78	97	78	115	97	96.67	18.5	500	24.47	
5	14.542	133	65	65	97	65	115	78	88.75	21.88	500	36.42	
6	14.685	142	64	64	78	64	115	65	83.8	21.95	500	38.88	
7	14.82	134	78	78	78	78	115	64	82.83	19.77	500	24.46	
8	14.955	134	91	91	78	91	115	64	84	18.31	500	18.6	
9	15.09	134	97	97	91	97	115	64	85.63	17.57	500	16.91	
10	15.225	134	109	109	97	109	115	64	88.22	18.19	500	13.57	
11	15.36	134	130	130	109	130	115	64	92.4	21.64	500	9.13	
12	15.494	133	142	142	130	142	130	64	96.91	25.4	500	7.45	
13	15.629	134	109	109	130	109	142	64	97.92	24.47	500	13.65	
14	15.771	141	75	75	130	75	142	64	96.15	24.28	500	30.93	
15	15.906	134	55	55	109	55	142	64	93.21	25.79	500	58.76	
16	16.059	152	55	55	75	55	142	55	90.67	26.74	500	62.08	
17	16.195	135	82	82	75	82	142	55	90.13	25.92	500	24.81	
18	16.348	152	122	122	82	122	142	55	92	26.26	500	10.4	
19	16.484	135	112	112	112	112	142	55	93.11	25.91	500	12.43	
20	16.637	152	70	70	112	70	142	55	91.89	25.73	500	35.48	
21	16.778	140	58	58	112	58	142	55	90.2	26.17	500	53.05	
22	16.936	157	82	82	82	82	142	55	89.81	25.57	500	24.16	
23	17.075	138	114	114	82	114	142	55	90.91	25.48	500	12.21	
24	17.222	146	126	126	114	126	142	55	92.43	25.95	500	9.29	
25	17.357	134	101	101	114	101	142	55	92.79	25.44	500	15.88	
26	17.516	158	76	76	114	76	142	55	92.12	25.13	500	25.66	
27	17.651	134	98	98	101	98	142	55	92.35	24.64	500	16.35	

Range output column data definitions

- A: TimeStamp:** The time stamp is generated by the EVK software so the data can easily be plotted on a graph, and it represents the time of start of the test. There is latency, due to the USB interface, to send and receive data to the sensor.
- B: Range Execution Time (ms):** The range execution time is measured by the software for the amount of time that the test was executed to the time the data was received over the USB interface to display the data.
- C: Range Val:** The range value read directly from RESULT__RANGE_VAL (0x0062) in the VL6180X part on the EVK. This value includes the crosstalk compensation.
- D: True Range:** The range value read directly from the VL6180X part on the EVK. There is no difference between this value and the Range Value.
- E: True Range Smoothed:** The Raw Range value read from RESULT__RANGE_RAW (0x0064) on the VL6180X that would show a range measured without any cross talk compensation.
- F to I: Max, Min, Mean, Standard Deviation:** Statistical data on the range data in mm gathered since the EVK software was started or the statistics were reset. Stopping and starting the capture will create a new file, but not reset the statistics.
- J: Rtn Signal Rate:** The actual count rate of return signal of light measured by the return sensor when the laser is active on the return array. This is calculated by the formula:

$$\frac{\text{RESULT_RANGE_RETURN_SIGNAL_COUNT (0x006C)}}{\text{RESULT_RANGE_RETURN_CONV_TIME (0x007C)}}$$

This data is read directly from the VL6180X. Note: There are two photon triggering arrays. The first array is the reference array to measure the time photons have left the laser and the second array is the return array used to measure the time that the photons traveled to the target and back to the sensor.

- K: Ref Signal Rate:** The actual count rate of return signal of light measured by the reference sensor when the laser is active. This is calculated by the formula:

$$\frac{\text{RESULT_RANGE_REFERENCE_SIGNAL_COUNT (0x0070)}}{\text{RESULT_RANGE_REFERENCE_CONV_TIME (0x0080)}}$$

- L: Rtn Signal Count:** This is the amount of sensor counts triggered by the return array on the VL6180X when the laser is active. This data is read directly from the VL6180X.

6.7 I²C log file

Each I²C log is stored in a uniquely named .txt file. The I²C log filename configuration is `i2c_output_DD_MMM_YYYY_HHMM_SS_sss.txt`.

Where:

- `DD_MMM_YYYY` is the date the log file was created, for example `07_May_2013`
- `HHMM` is the time the log file was created, for example `1553`
- `SS_sss` is the time (seconds, milliseconds) the log file was created, for example `17_367`.

An example of a I²C log is shown in [Figure 64](#).

Figure 64. I²C log file example

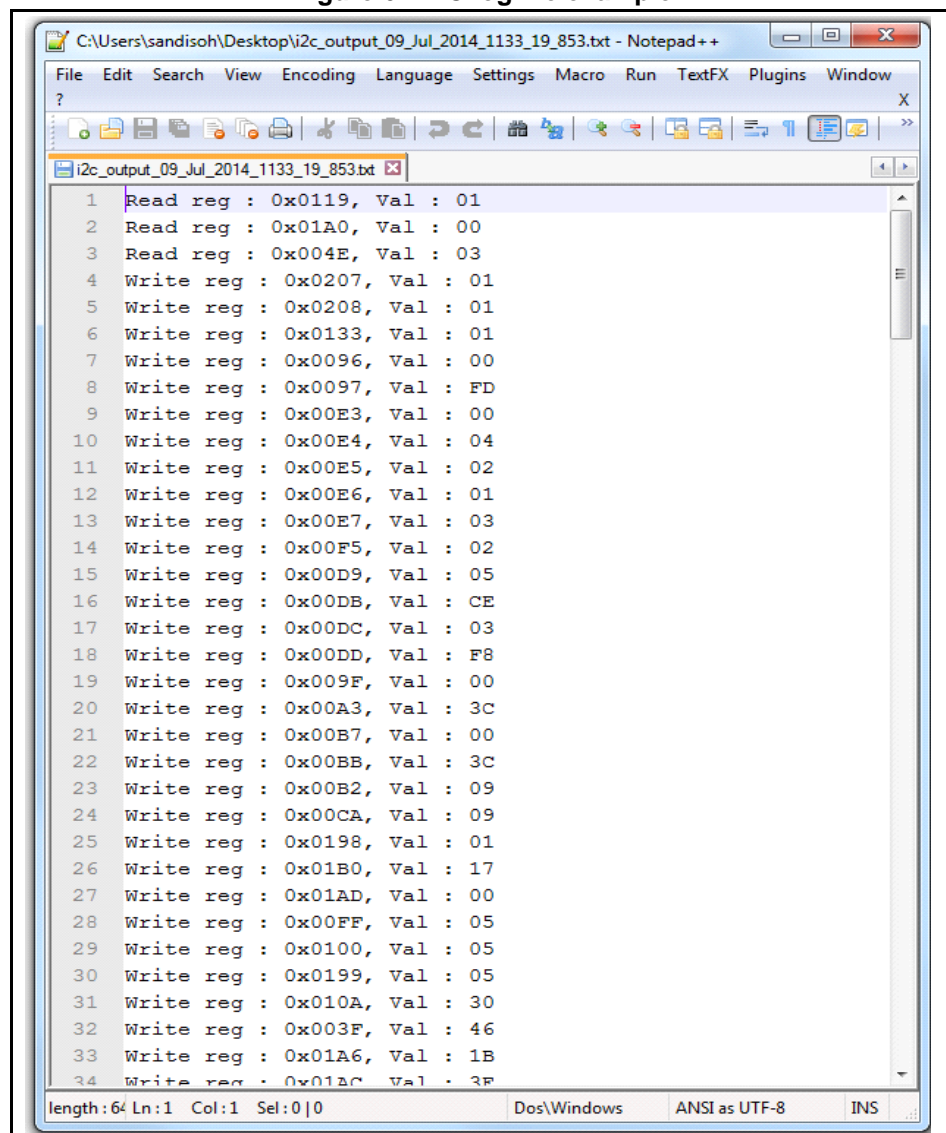

```
i2c_output_09_Jul_2014_1133_19_853.txt
1 Read reg : 0x0119, Val : 01
2 Read reg : 0x01A0, Val : 00
3 Read reg : 0x004E, Val : 03
4 Write reg : 0x0207, Val : 01
5 Write reg : 0x0208, Val : 01
6 Write reg : 0x0133, Val : 01
7 Write reg : 0x0096, Val : 00
8 Write reg : 0x0097, Val : FD
9 Write reg : 0x00E3, Val : 00
10 Write reg : 0x00E4, Val : 04
11 Write reg : 0x00E5, Val : 02
12 Write reg : 0x00E6, Val : 01
13 Write reg : 0x00E7, Val : 03
14 Write reg : 0x00F5, Val : 02
15 Write reg : 0x00D9, Val : 05
16 Write reg : 0x00DB, Val : CE
17 Write reg : 0x00DC, Val : 03
18 Write reg : 0x00DD, Val : F8
19 Write reg : 0x009F, Val : 00
20 Write reg : 0x00A3, Val : 3C
21 Write reg : 0x00B7, Val : 00
22 Write reg : 0x00BB, Val : 3C
23 Write reg : 0x00B2, Val : 09
24 Write reg : 0x00CA, Val : 09
25 Write reg : 0x0198, Val : 01
26 Write reg : 0x01B0, Val : 17
27 Write reg : 0x01AD, Val : 00
28 Write reg : 0x00FF, Val : 05
29 Write reg : 0x0100, Val : 05
30 Write reg : 0x0199, Val : 05
31 Write reg : 0x010A, Val : 30
32 Write reg : 0x003F, Val : 46
33 Write reg : 0x01A6, Val : 1B
34 Write reg : 0x01A0, Val : 3F
```

7 Application programming interface (API)

The VL6180X API is a set of C functions controlling the VL6180X (init, ranging, ALS,...) to enable the development of end-user applications. This API is structured in a way it can be compiled on any kind of platforms through a well isolated platform layer (mainly for low level I2C access). Several code examples are provided to show how to use API and perform ranging and ALS measures. A complete Nucleo F401 + VL6180X expansion board project is also provided (Keil IDE required to compile the project) as well as the pre-compiled binary that can be directly used.

API download

To download VL6180X API:

- on st.com, search for “VL6180X”
- on next page select: “VL6180X”
- On next page select “design resources”
- On “design resources” page select “STSW-IMG003”
- On next page “download”

Quick start guide for API integration

API documentation is in the “docs” folder and is available in two formats:

- API_Documentation_proximity.chm
- API_Documentation_proximity.html

The VL6180X API is integrated in a software project in two steps

1. Developer has to add/link the files listed in [Table 8](#) and in [Figure 65](#) to his source and include code path. Some files may require modifications to comply with the final application or the hardware/software capabilities.

Table 8. API header files

Names	Description
vl6180x_cfg.h	Application configuration May require modification
vl6180x_api.c and vl6180x_api.h	All operating functions at high and low level to control the sensor Must not be modified
vl6180x_def.h	Definition of constants and structures used in the API Must not be modified
vl6180x_platform.h	Target platform specific declarations/prototypes May require modification
vl6180x_types.h	Basic types definition May require porting

2. To manage the data communication between the VL6180X and the host, the developer has to design a camera control interface (CCI) register communication driver. The API low-level functions rely on the following set of 7 read & write functions which perform CCI register access to the device:
`VL6180x_WrByte(); VL6180x_WrWord(); VL6180x_WrDWord();`

`VL6180x_UpdateByte()`; `VL6180x_RdByte()`; `VL6180x_RdWord()`;
`VL6180x_RdDWord()`.

To implement these 7 functions, it is recommended to use `vl6180x_i2c.c` and `vl6180x_i2c.h` files in `platform/cci_i2c` directory (see [Figure 65](#))

Note: Detailed information on these functions can be found in section `Modules/CCI to RAW I2C translation layer of the API_Documentation_(version)_proximity.chm` delivery

Figure 65. Iheader and CCI service files in the API

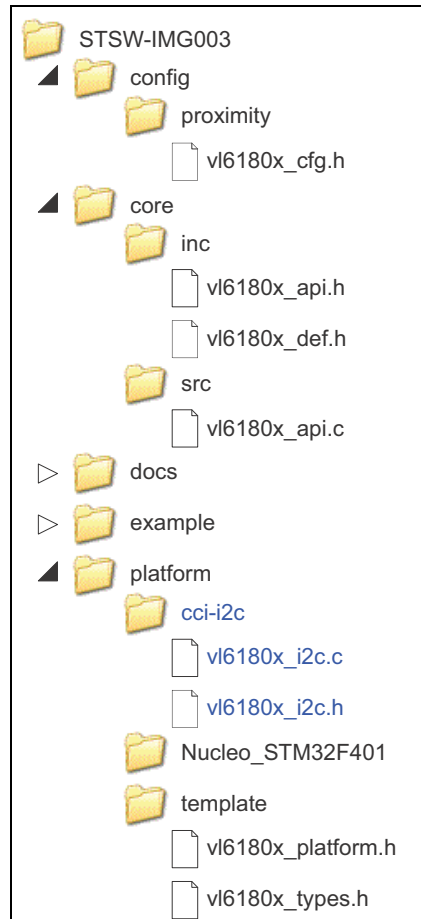

8 Revision history

Table 9. Document revision history

Date	Revision	Changes
09-Jun-2015	1	Initial release.
03-Aug-2015	2	Replace STSW-LINK008 by STSW-LINK009 Add Chapter 7: Application programming interface (API)
05-Nov-2015	3	Add support of STM32L476 Add Section 5.4: "GestureDetect1" demonstration

IMPORTANT NOTICE – PLEASE READ CAREFULLY

STMicroelectronics NV and its subsidiaries ("ST") reserve the right to make changes, corrections, enhancements, modifications, and improvements to ST products and/or to this document at any time without notice. Purchasers should obtain the latest relevant information on ST products before placing orders. ST products are sold pursuant to ST's terms and conditions of sale in place at the time of order acknowledgement.

Purchasers are solely responsible for the choice, selection, and use of ST products and ST assumes no liability for application assistance or the design of Purchasers' products.

No license, express or implied, to any intellectual property right is granted by ST herein.

Resale of ST products with provisions different from the information set forth herein shall void any warranty granted by ST for such product.

ST and the ST logo are trademarks of ST. All other product or service names are the property of their respective owners.

Information in this document supersedes and replaces information previously supplied in any prior versions of this document.

© 2015 STMicroelectronics – All rights reserved